



CS-417 INTRODUCTION TO ROBOTICS AND INTELLIGENT SYSTEMS

Actuators

Slides by P. Giguere

What is an actuator?

- Device for moving or controlling a system.
- “Robot Muscles”



Hydraulic Actuators

- Pros:
 - Powerful
 - Fast
 - Stiff
- Cons
 - Messy
 - Maintenance
 - External Pump



Hydraulic Actuator Application

- BigDog from Boston Dynamics



Pneumatic Actuators

- Pros:
 - Powerful
 - Cheap
- Cons
 - Soft/Compliant
 - External Compressor

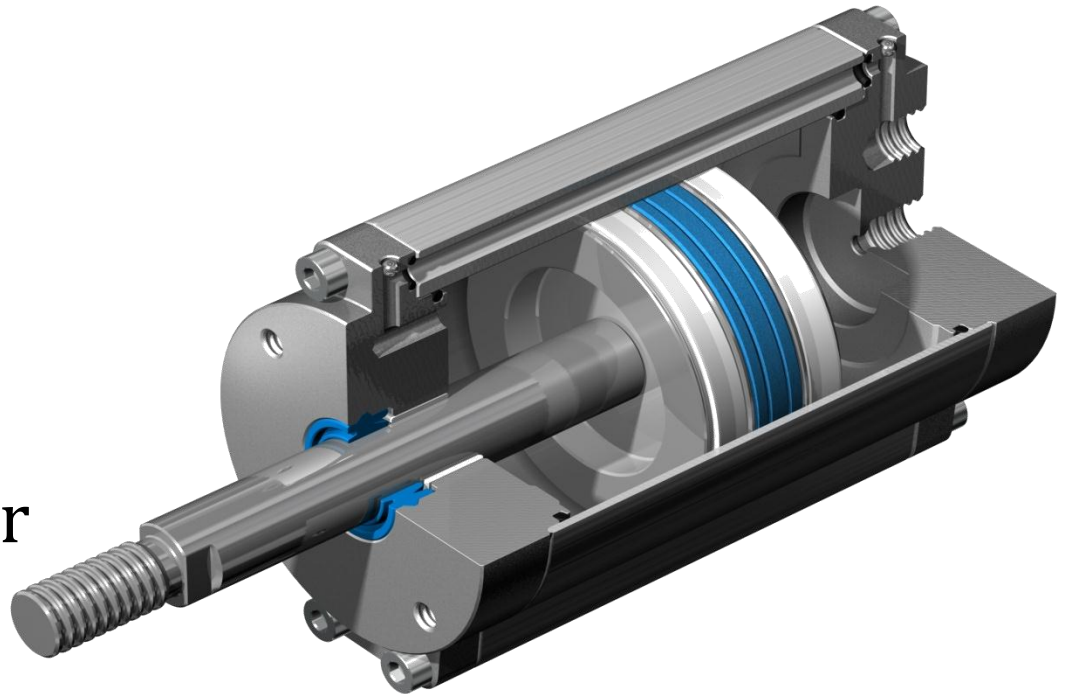

Pneumatic Actuators

- 3D Biped ('89-'95) from MIT Leg Lab

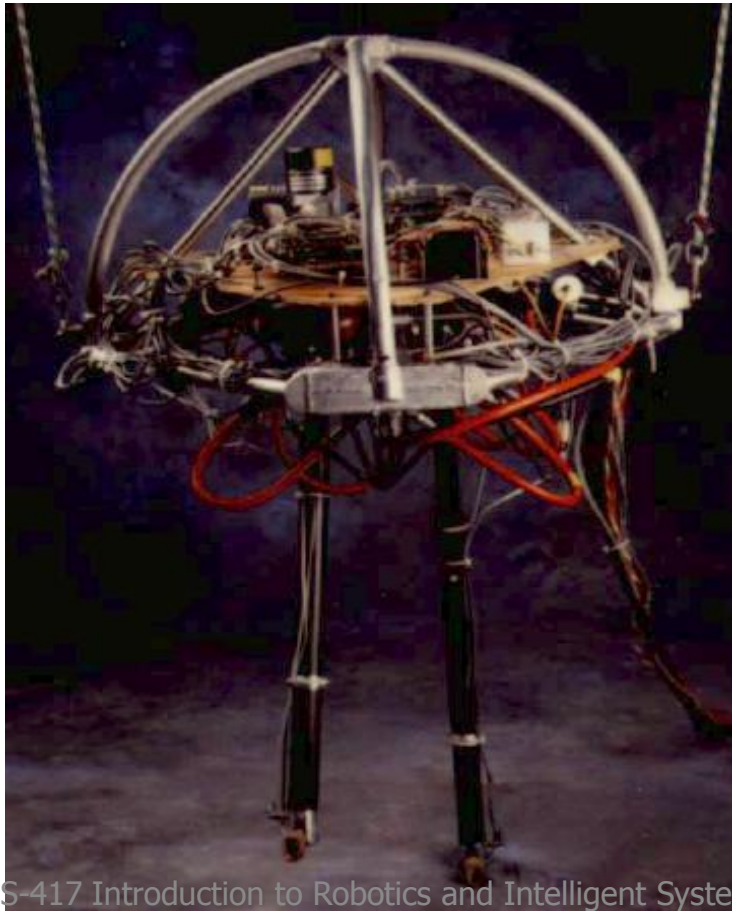

Air Muscle

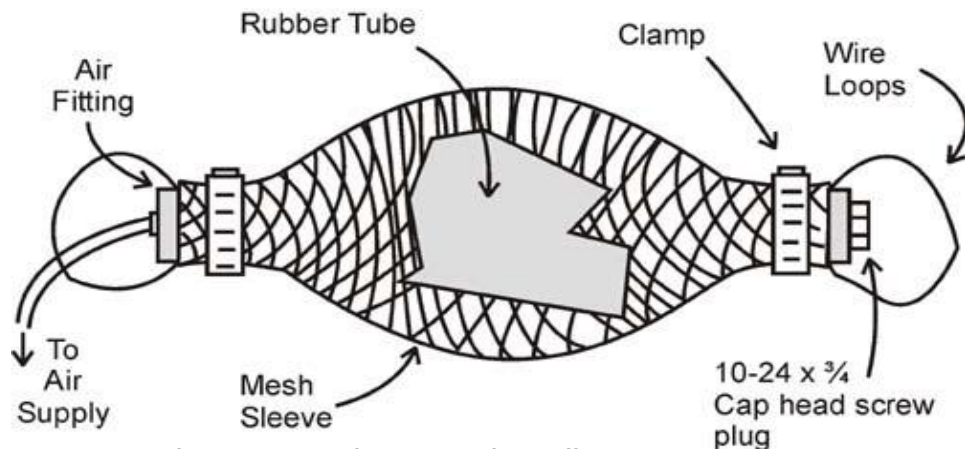
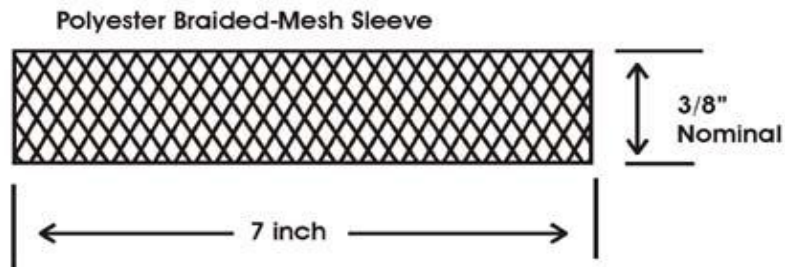
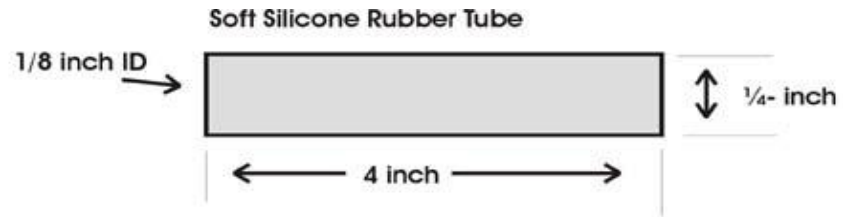

Air Muscle Application

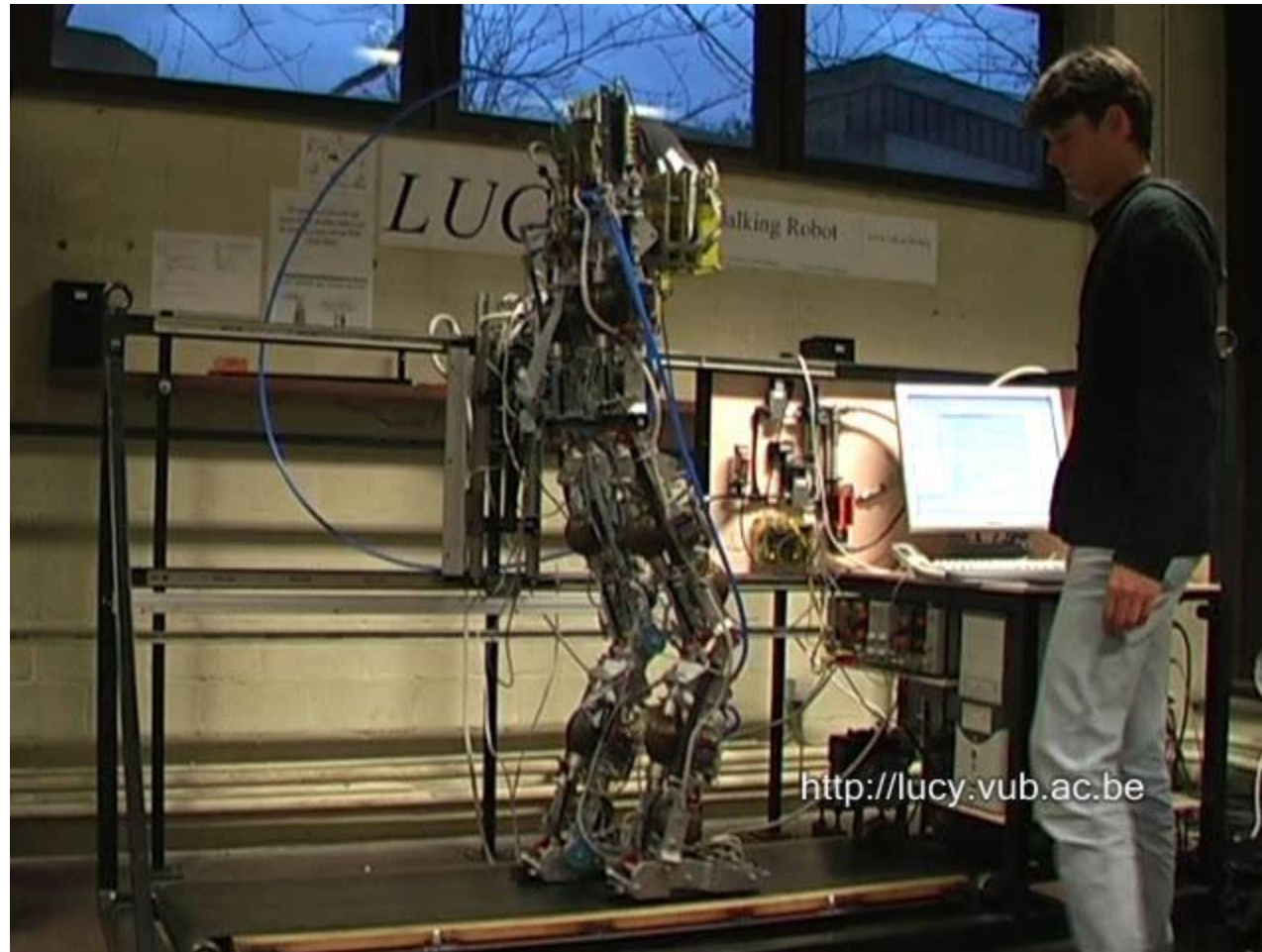

Air Muscle Application



Shape Memory Alloy Actuators

- Works by warming and cooling Nitinol wires.
- Pros:
 - Light
 - Powerful
- Cons:
 - Slow (cooling)

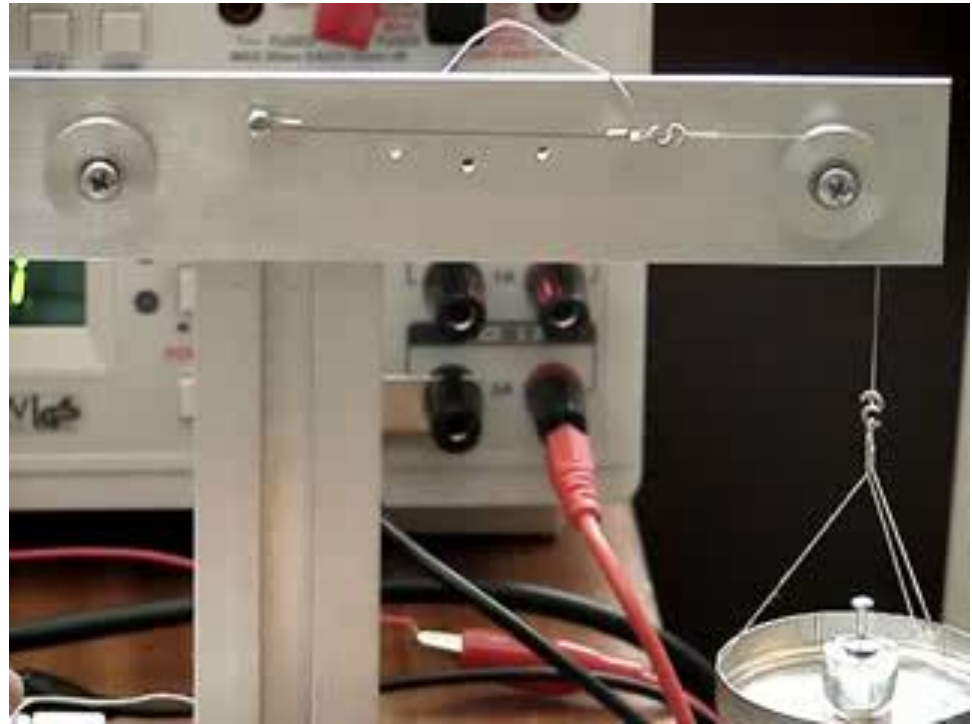

Stiquito

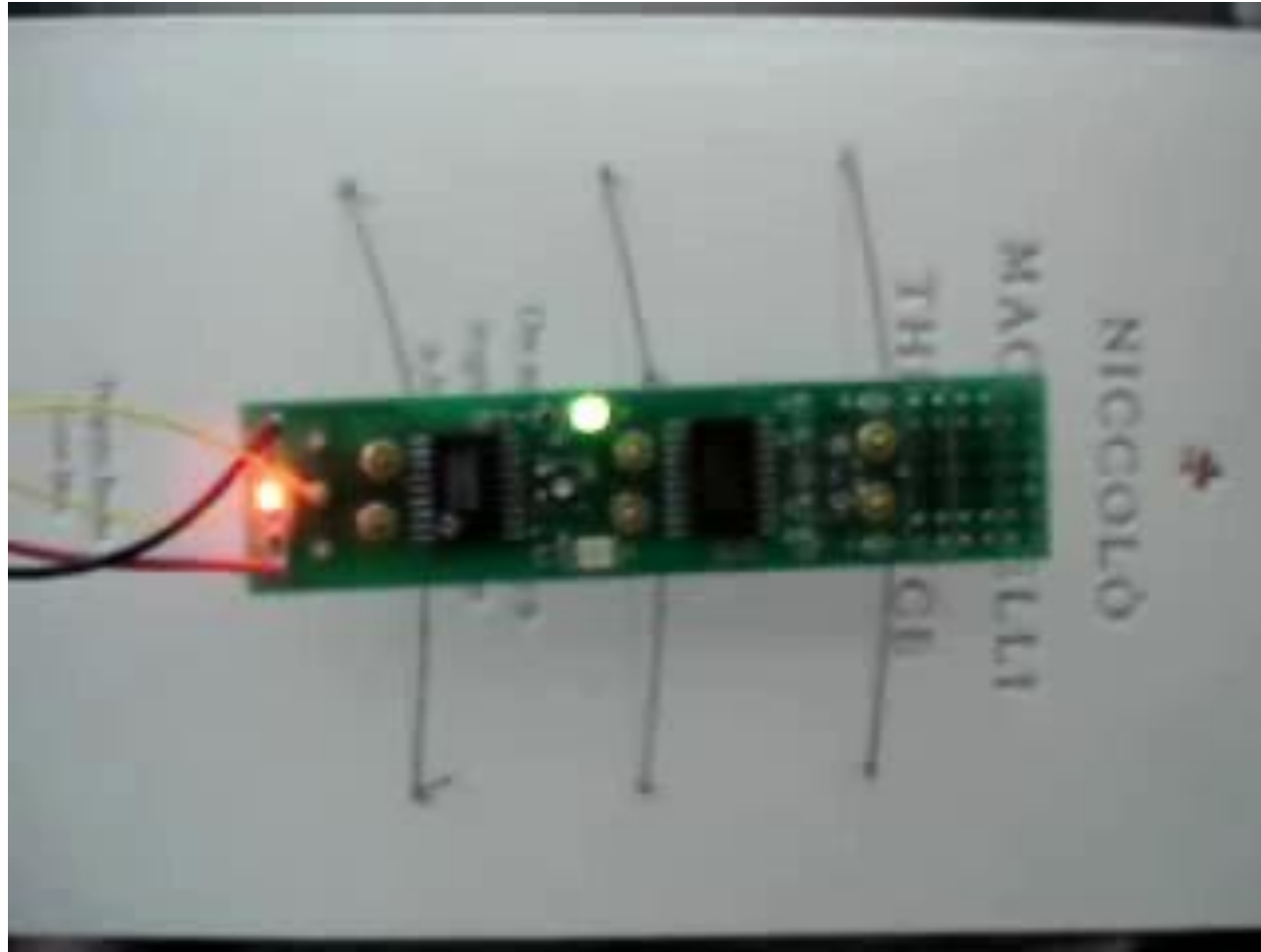

Jonathan Mills, Indiana University



Electric Actuators

- Pros
 - Better position precision
 - Well understood
 - No separate power source
 - Cheap
- Cons
 - Heavy
 - Weaker/slower than hydraulics
 - Cooling issue



Electric Actuators

- Stepper motors
- DC motors
 - Servos
 - Continuous
 - Position
- Others (not discussed)
 - Linear actuators
 - AC motors



Stepper Motor Basics

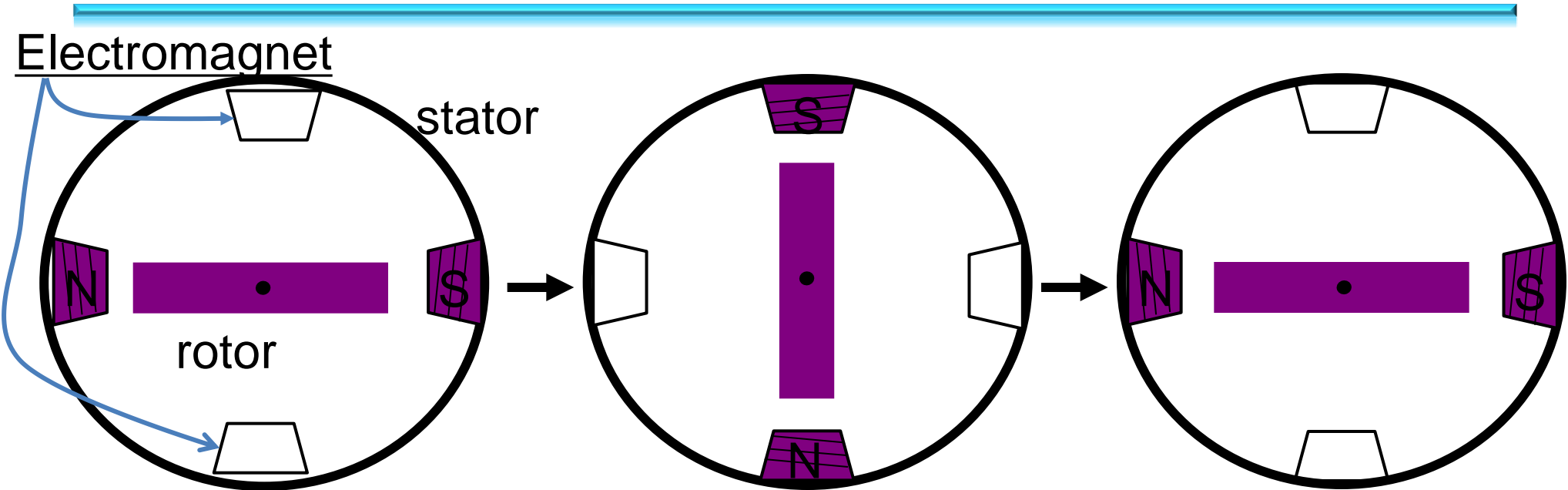

Stator: made out of coils of wire called “winding”

Rotor: magnet rotates on bearings inside the stator

- Direct control of rotor position (no sensing needed)
- May oscillate around a desired orientation (resonance at low speeds)
- Low resolution

printers
computer drives



Increased Resolution

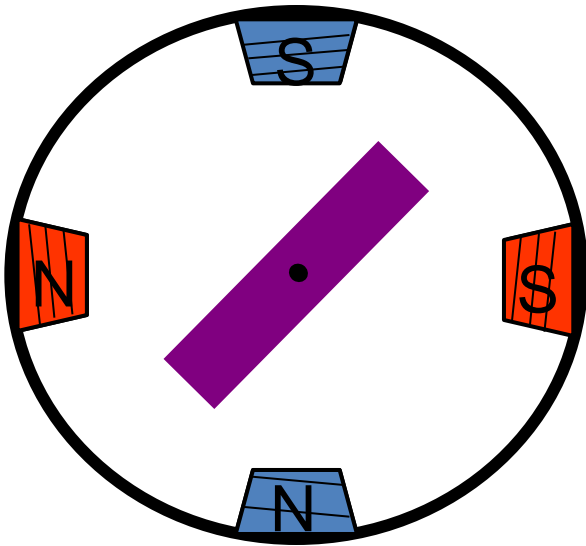

Half stepping

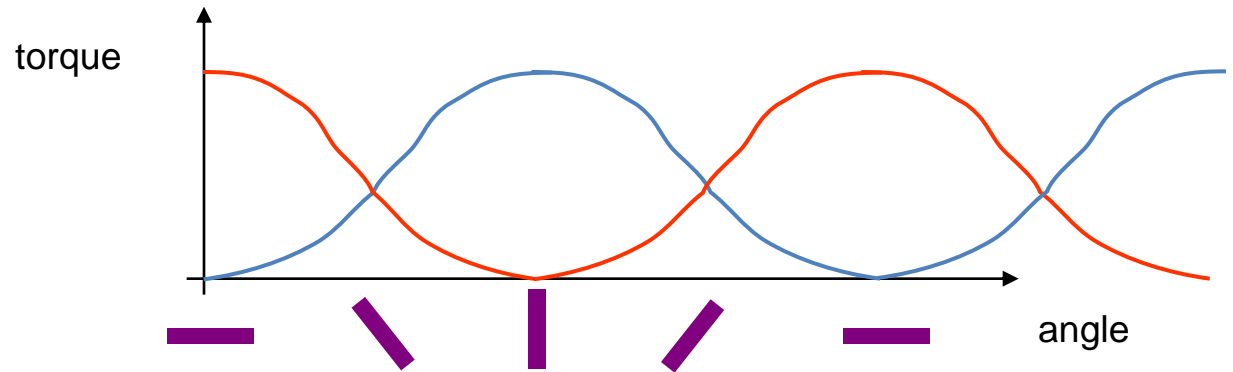

Increased Resolution

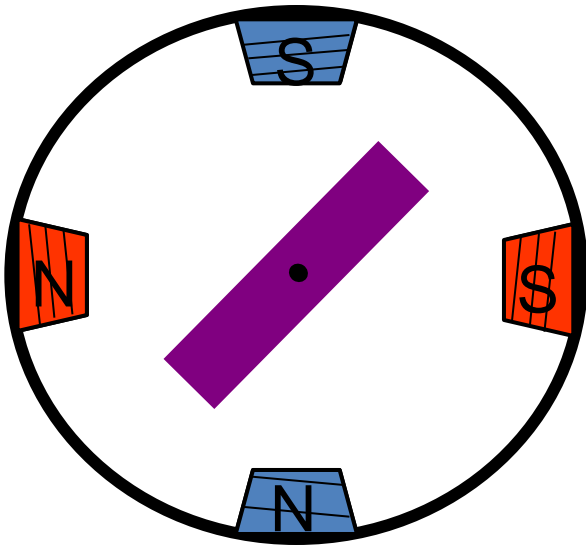

Half stepping

More teeth on rotor or stator

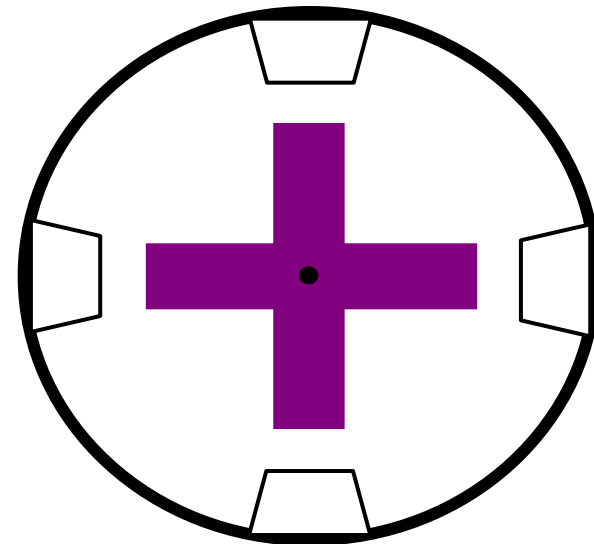

Increased Resolution

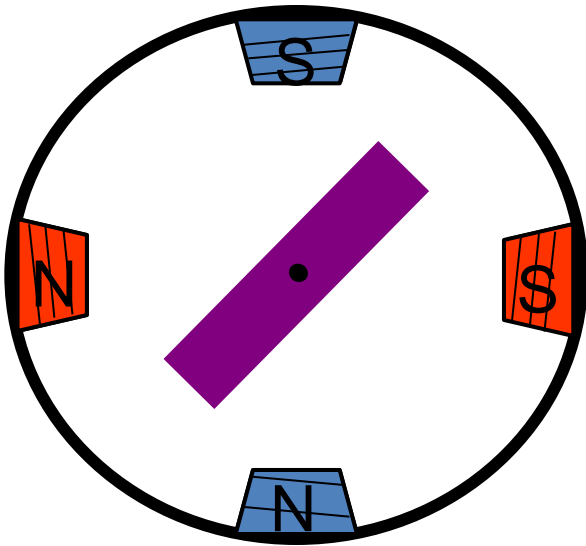

Half stepping

More teeth on rotor or stator

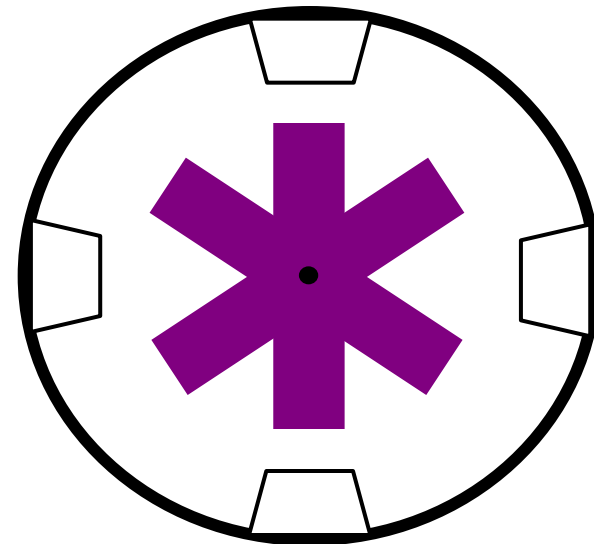

More Teeth on Rotor

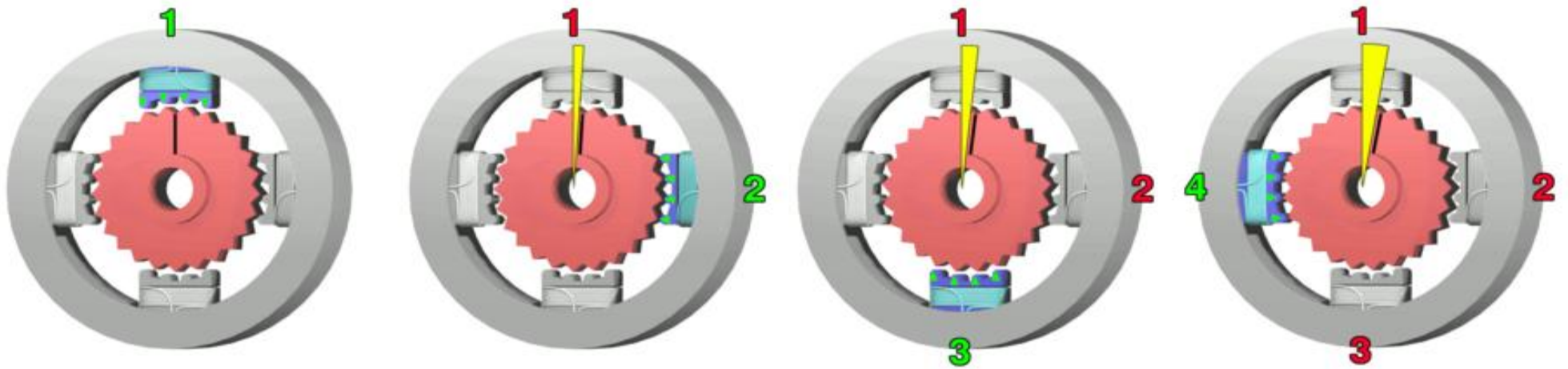

Stepper Motors

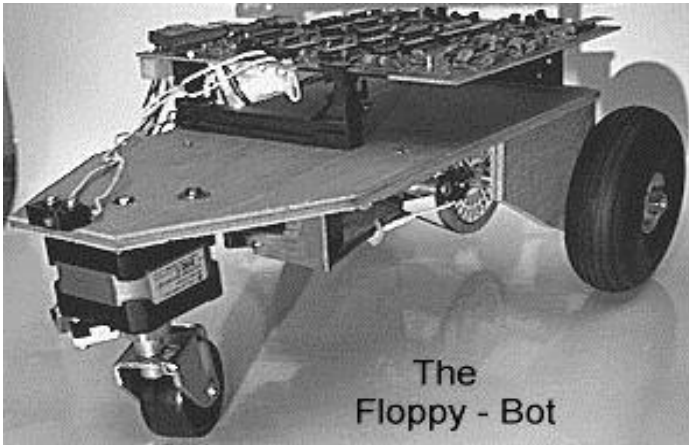

- Pros:
 - Direct position control
 - Precise positioning
 - Easy to control

- Cons:
 - Oscillations
 - Low torque at high speeds



DC motors -- exposed !

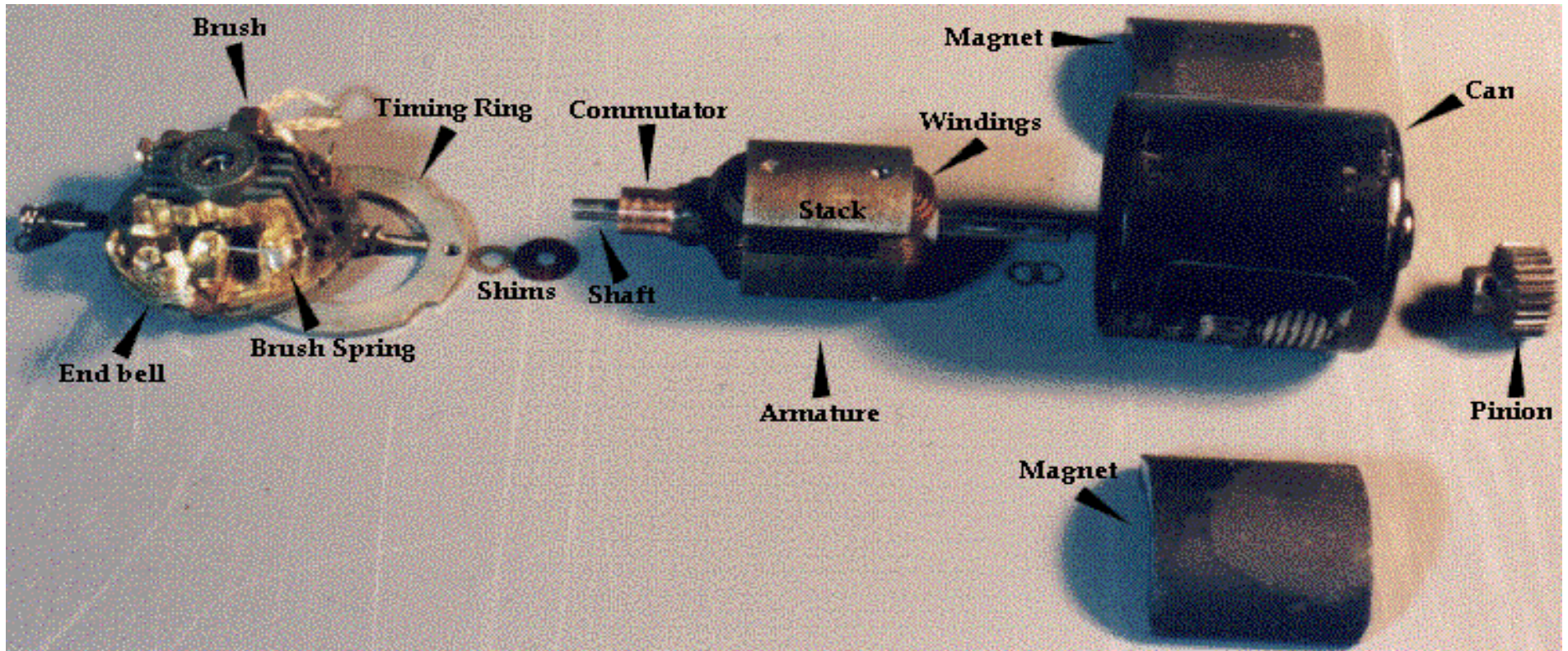

DC motor basics

permanent magnets

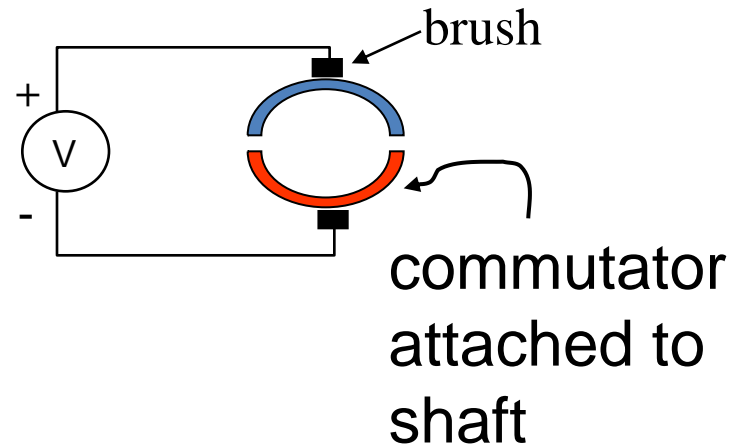
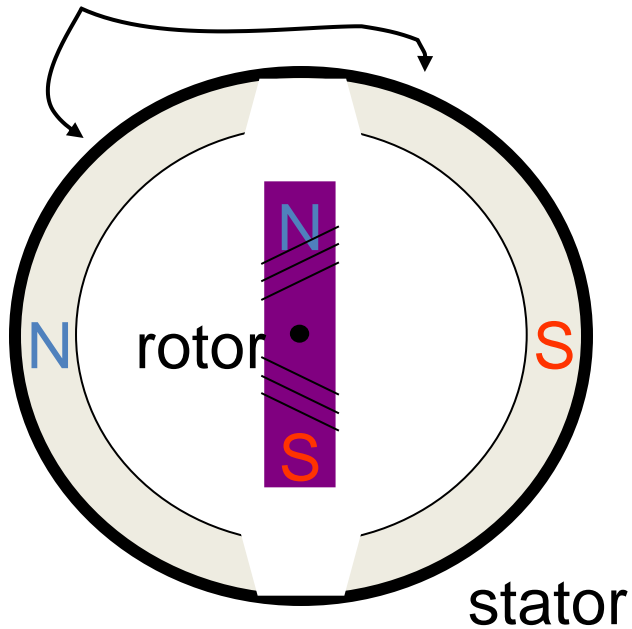

DC motor basics

permanent magnets

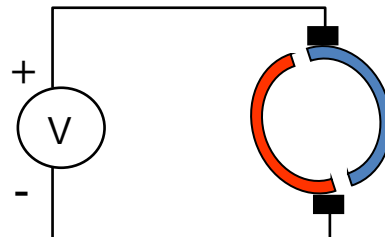
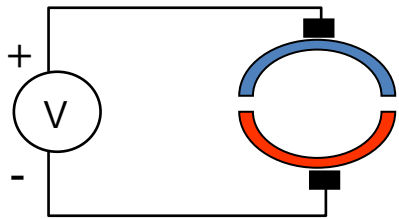
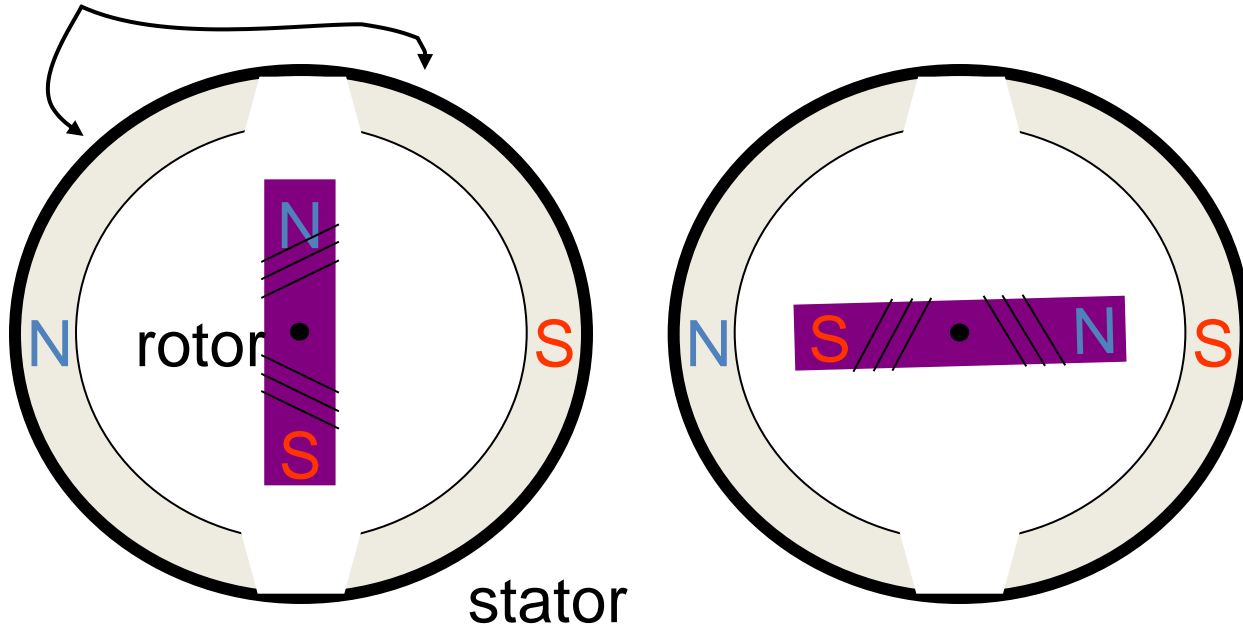

DC motor basics

permanent magnets

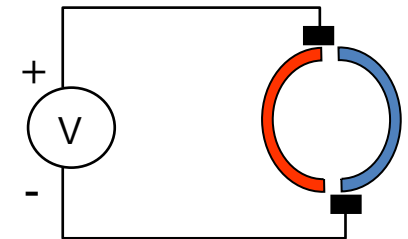
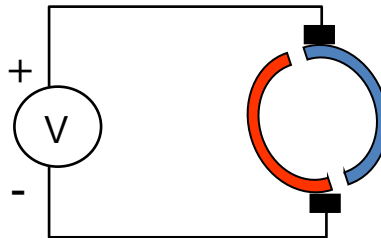
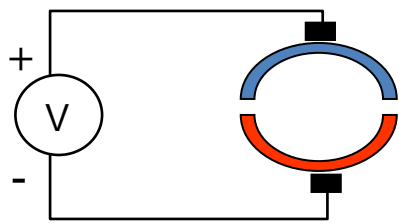
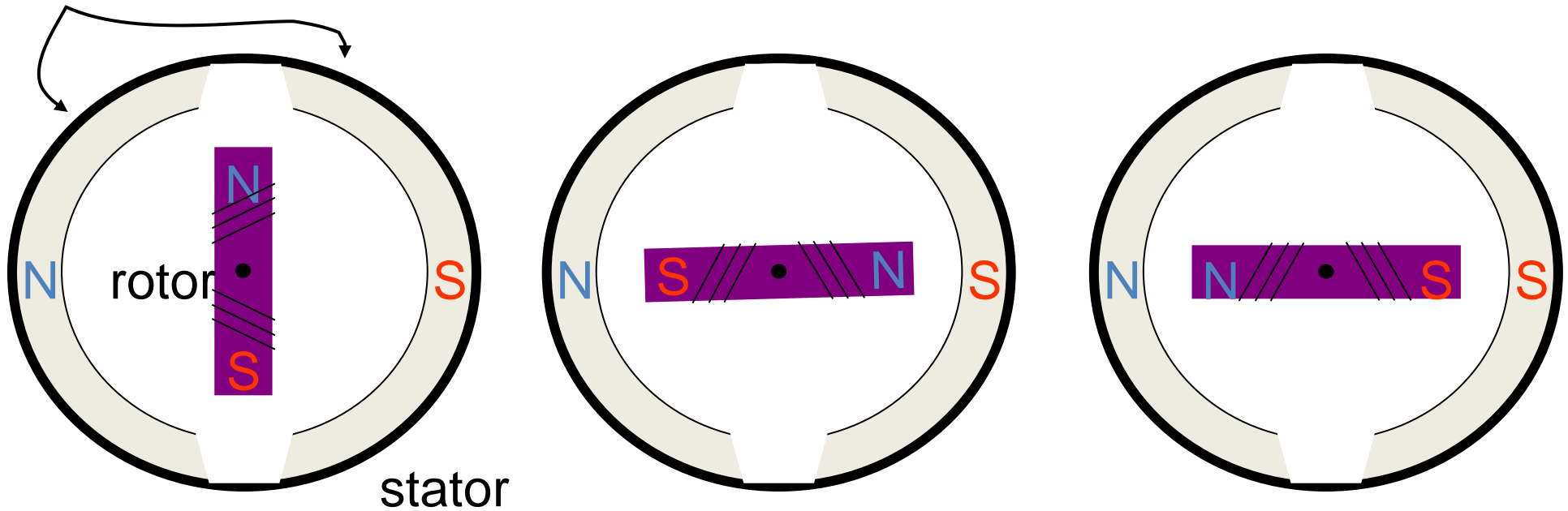

DC motor back-EMF

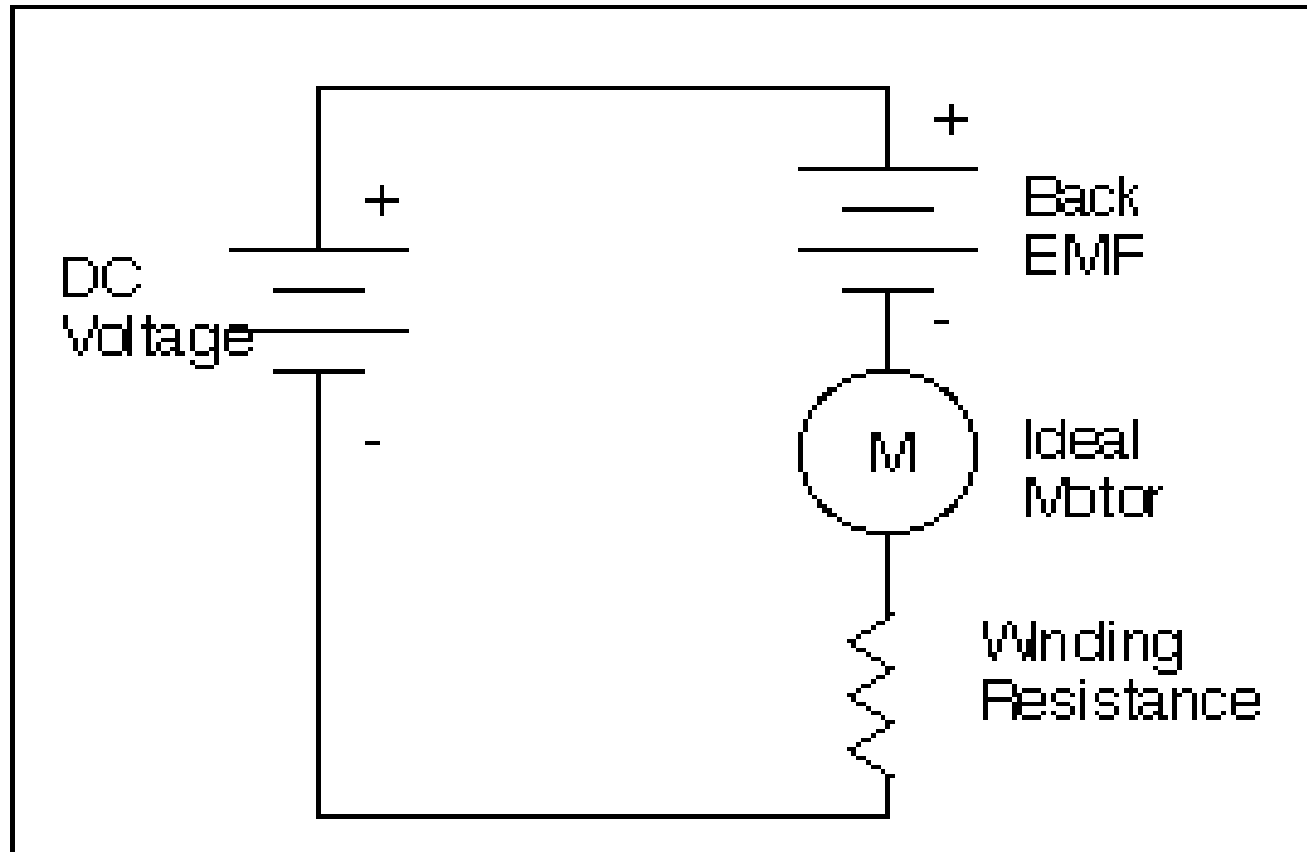

DC motor torque τ

τ = torque

I = current

$$\tau \propto I$$

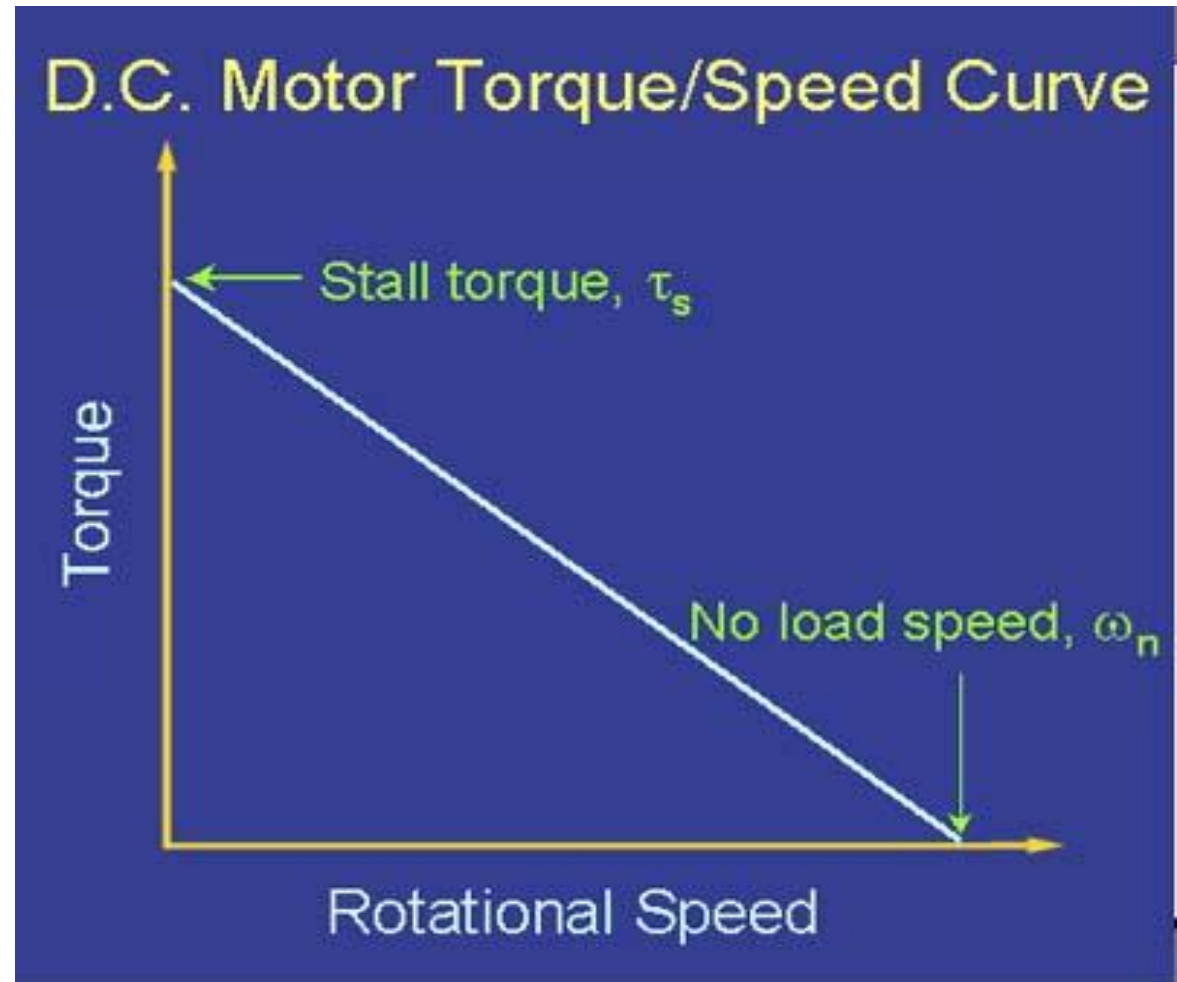

Commercial Electric Hobby “Servos”

- Same as ones found on your robot.
- Dirt cheap (~10\$)
- Comes in two flavors:
 - “standard”
 - Position
 - Continuous
 - Rotation rate



Internals of “Hobby” Servo



Commercial Electric Hobby “Servos”

- Use PWM for commands:

