

Configuration Space

Configuration Space

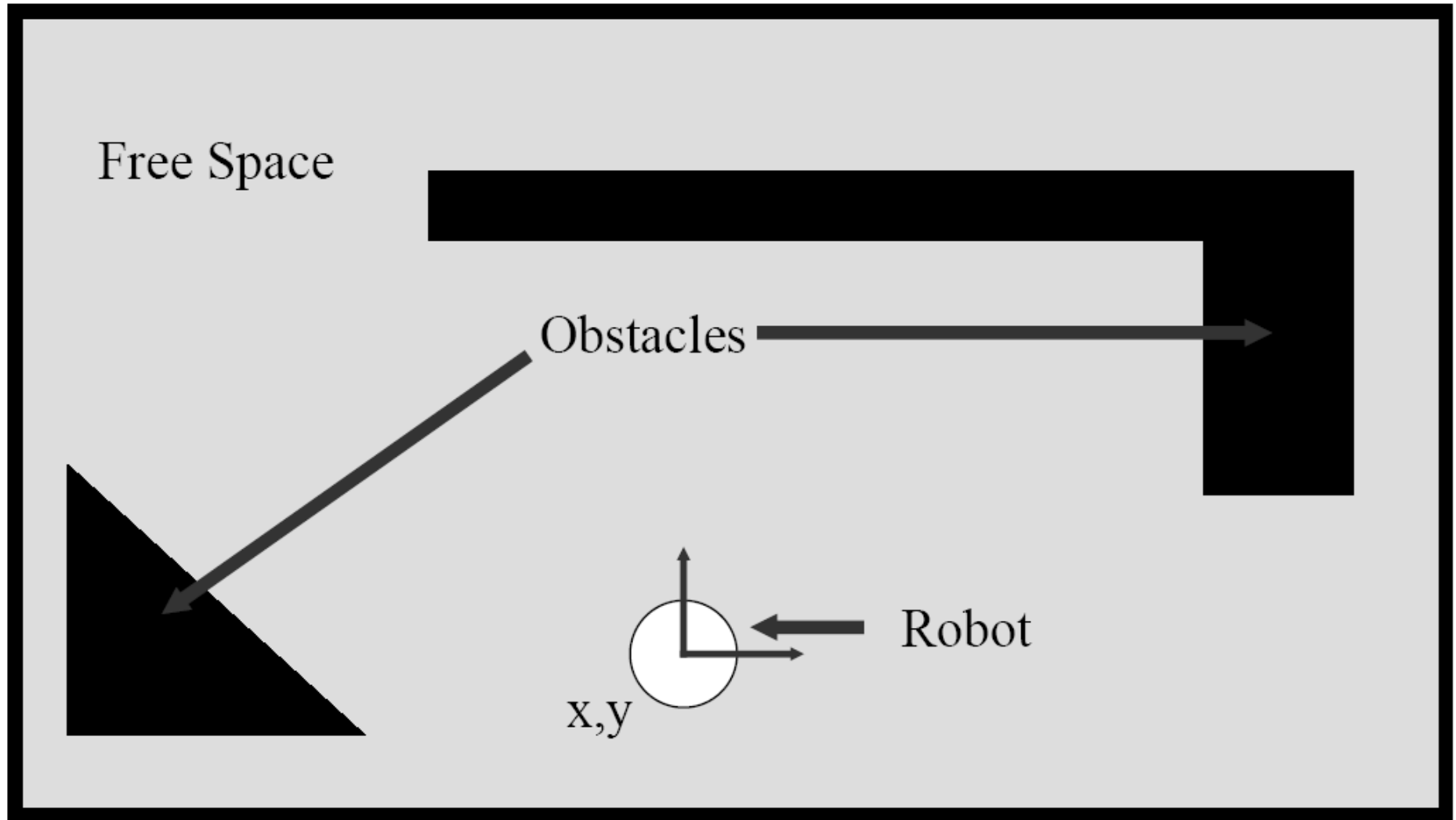

Configuration Space

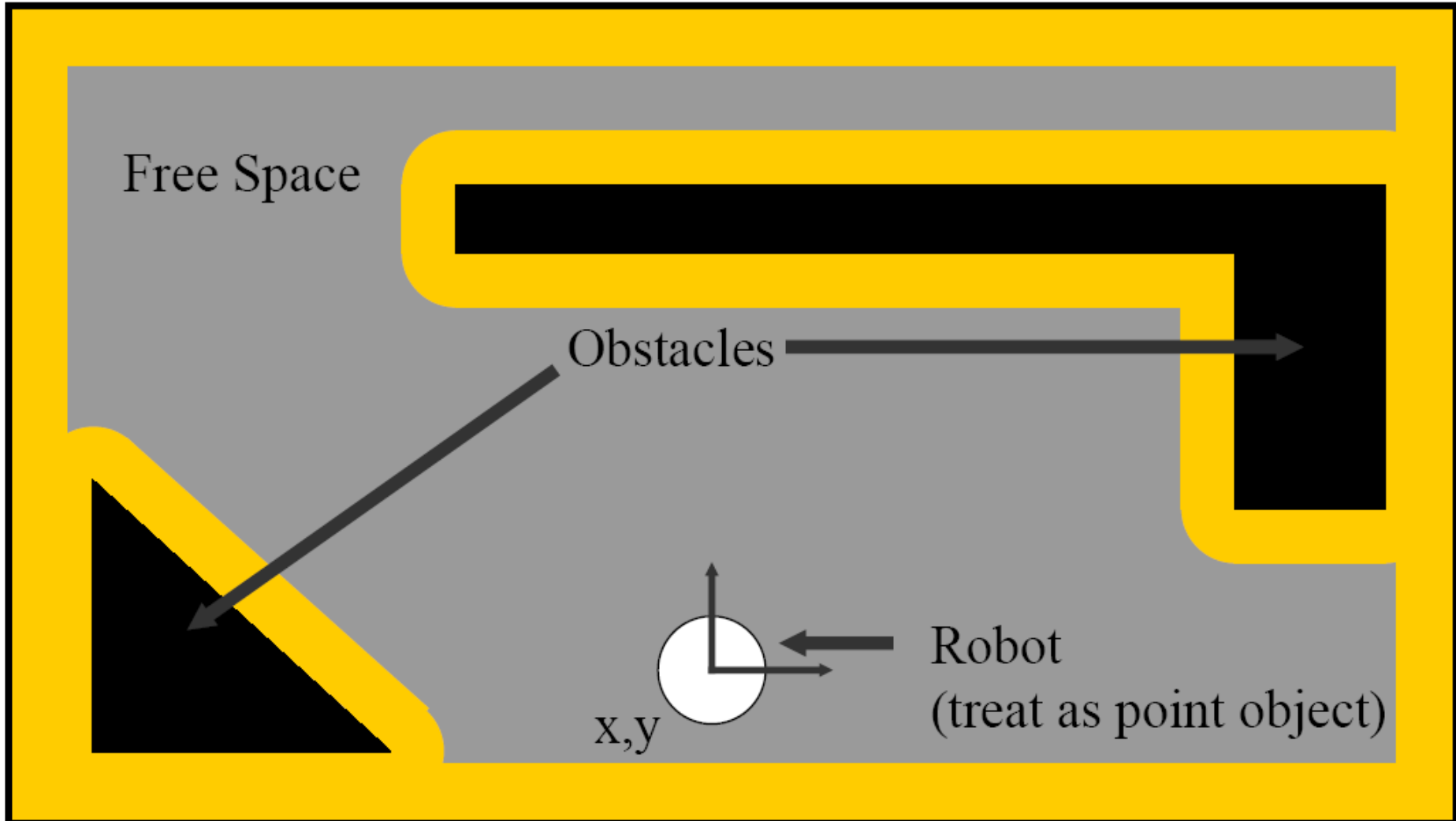

Definition

- A robot **configuration** is a specification of the positions of all robot points relative to a fixed coordinate system
- Usually a configuration is expressed as a "**vector**" of position/orientation parameters

What is a Path?

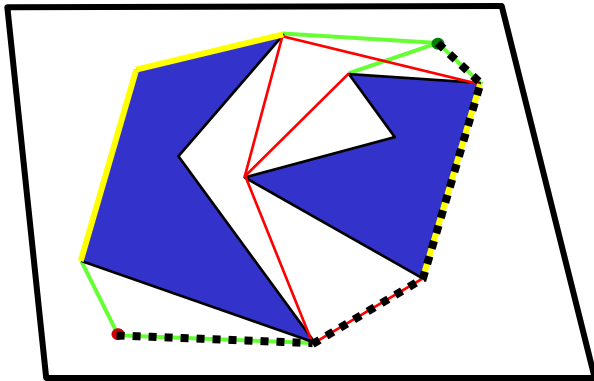

- q_{init}
 - q_{goal}
- 1



•

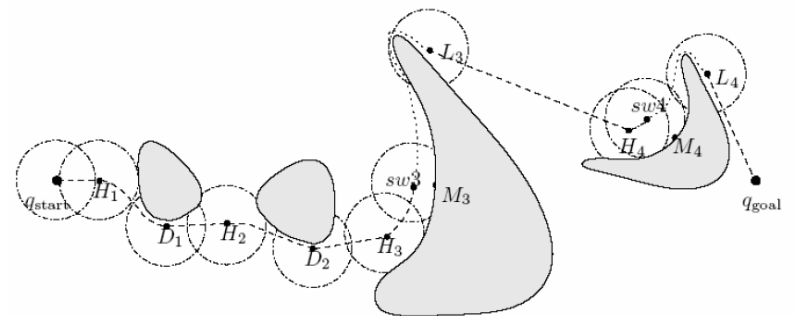
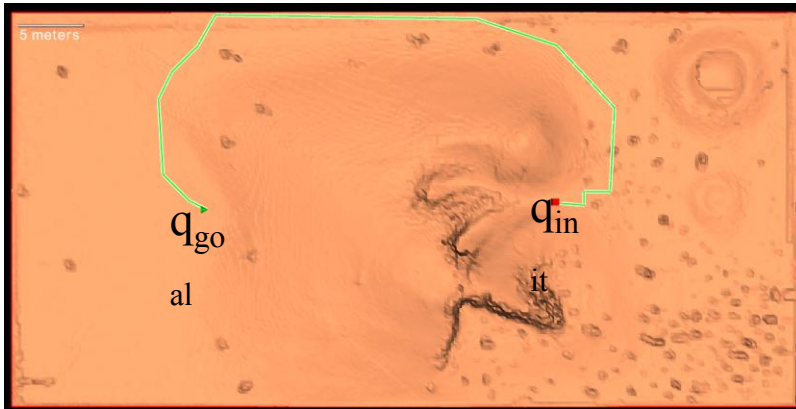

What is a Path?

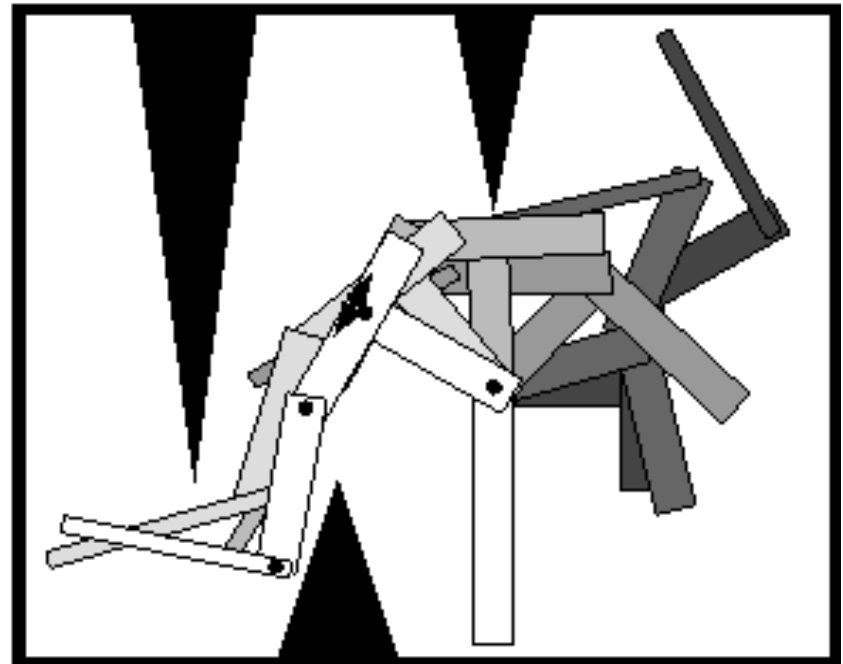
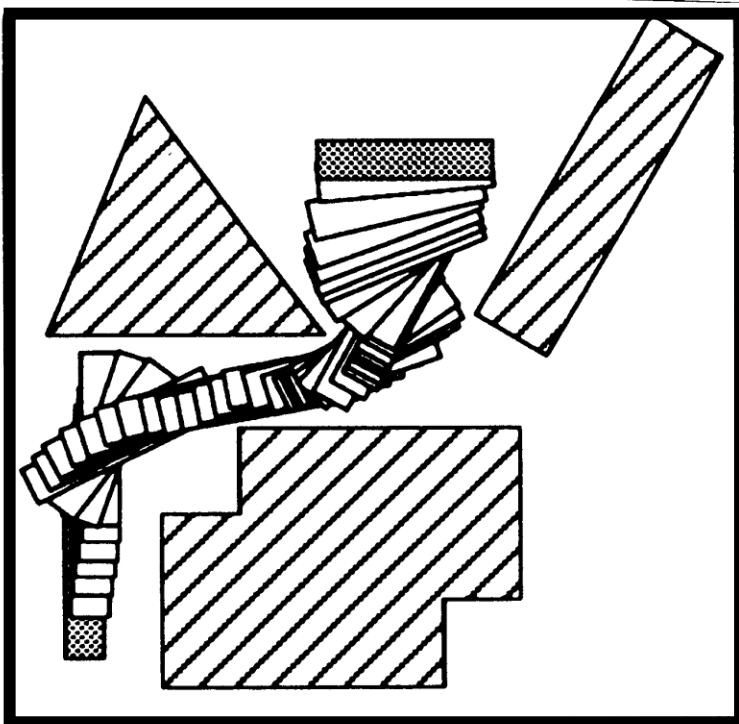

Tool: Configuration Space (C-Space C)

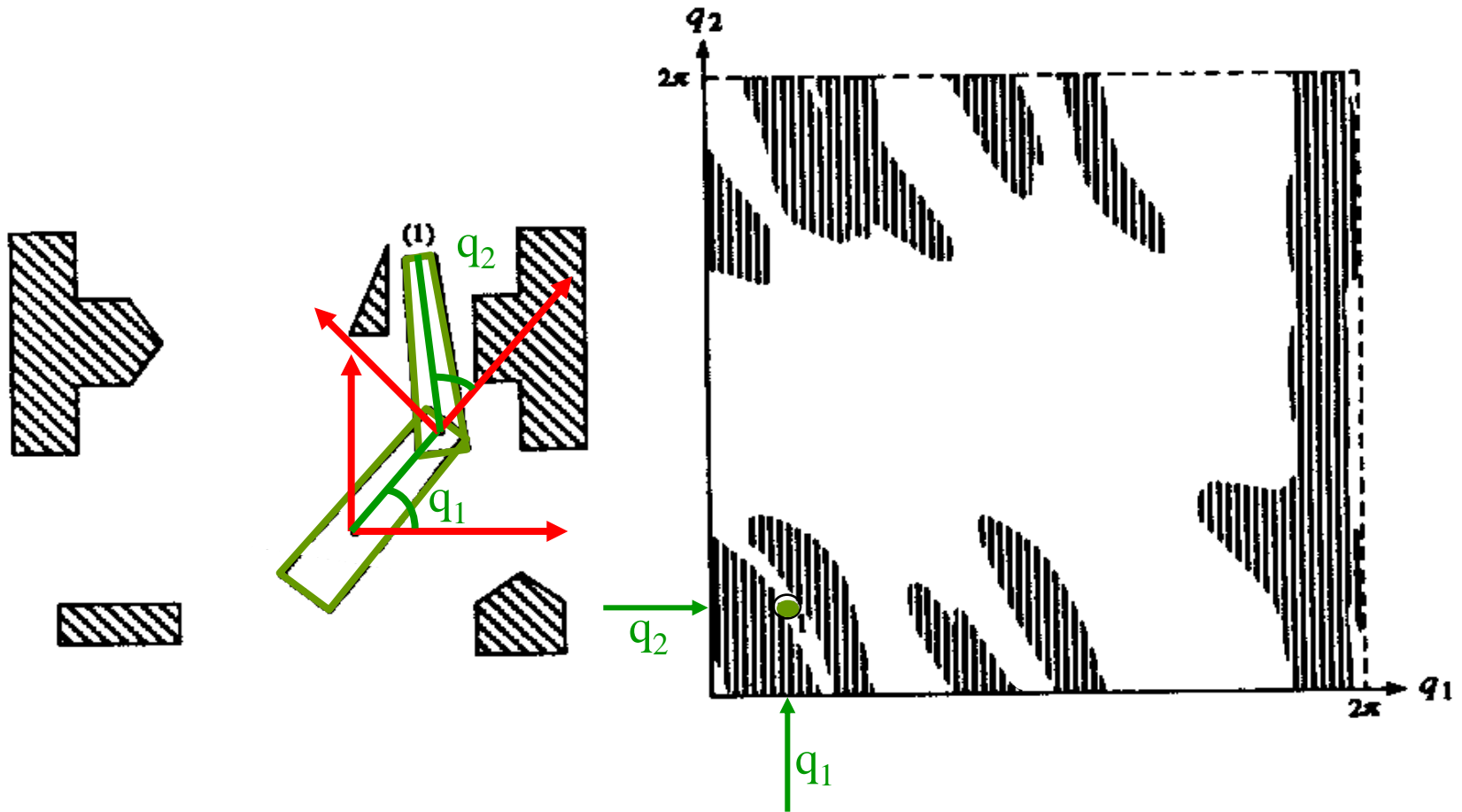

Tool: Configuration Space (C-Space C)

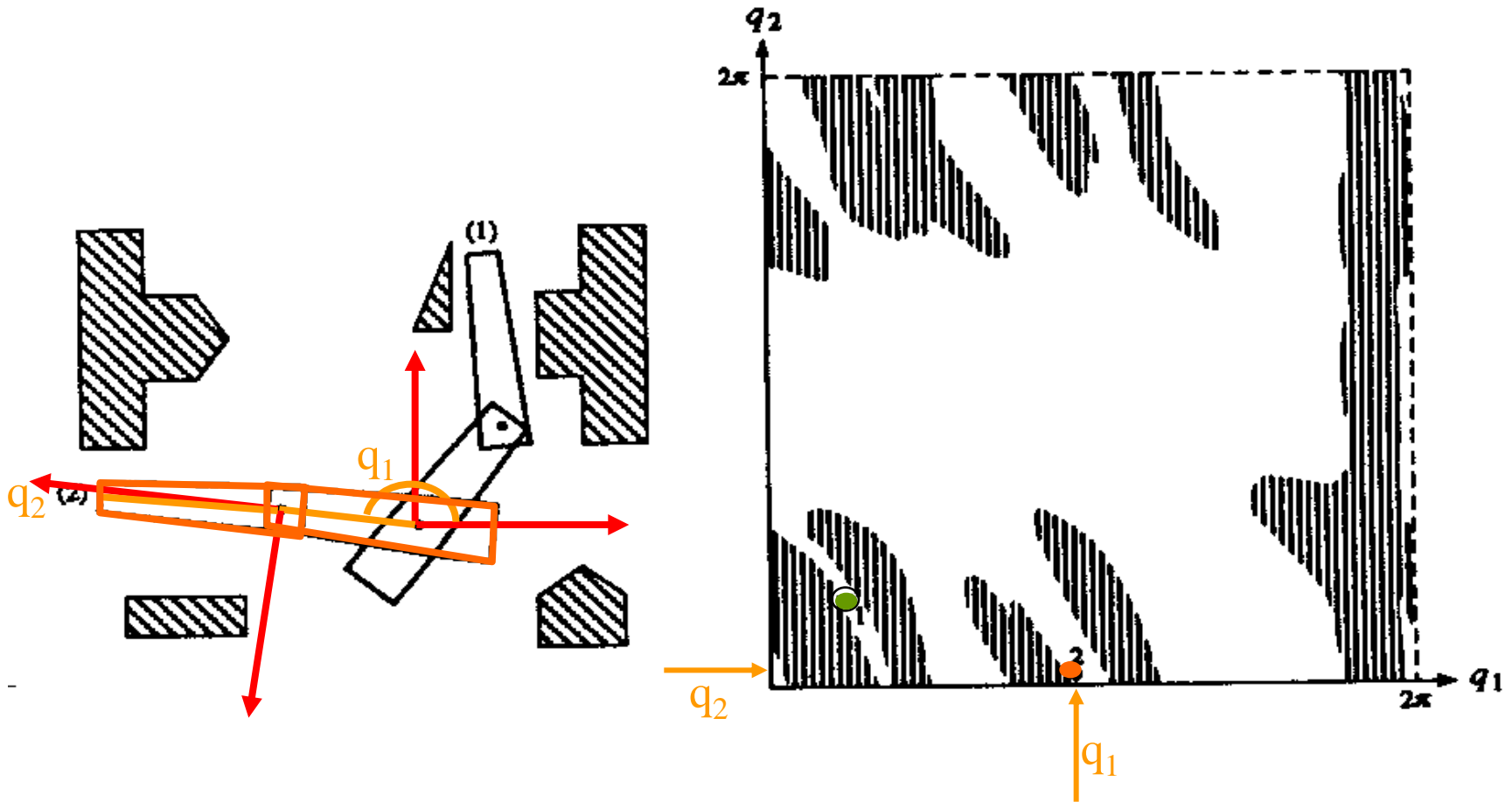

Tool: Configuration Space (C-Space C)

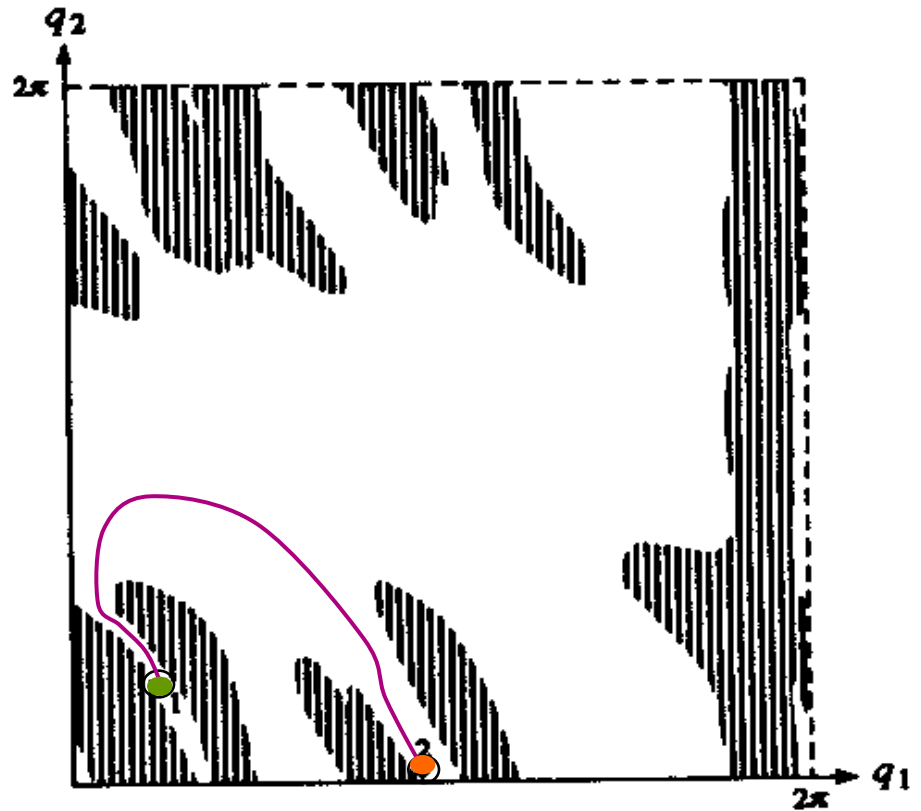
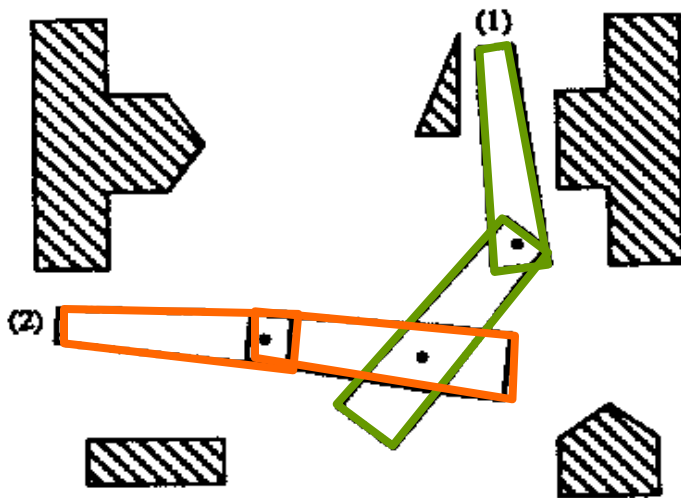

Articulated Robot Example

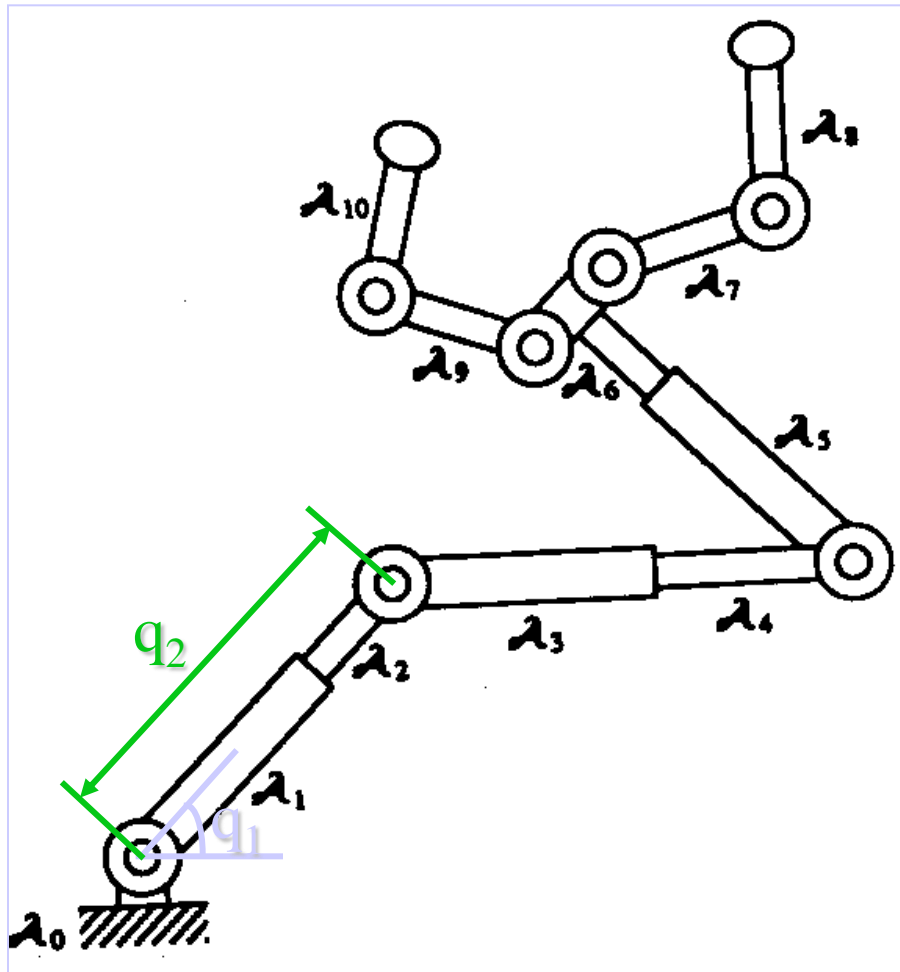

$$q = (q_1, q_2, \dots, q_{10})$$

Configuration Space of a Robot

- Space of all its possible configurations
- But the topology of this space is usually not that of a Cartesian space

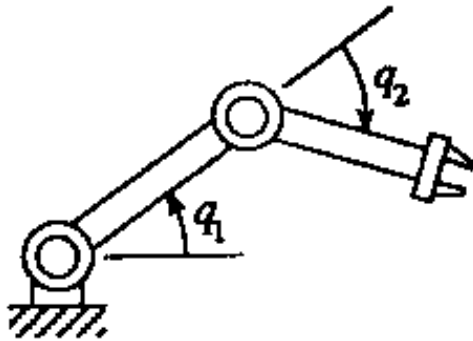

Configuration Space of a Robot

- Space of all its possible configurations
- But the topology of this space is usually not that of a Cartesian space

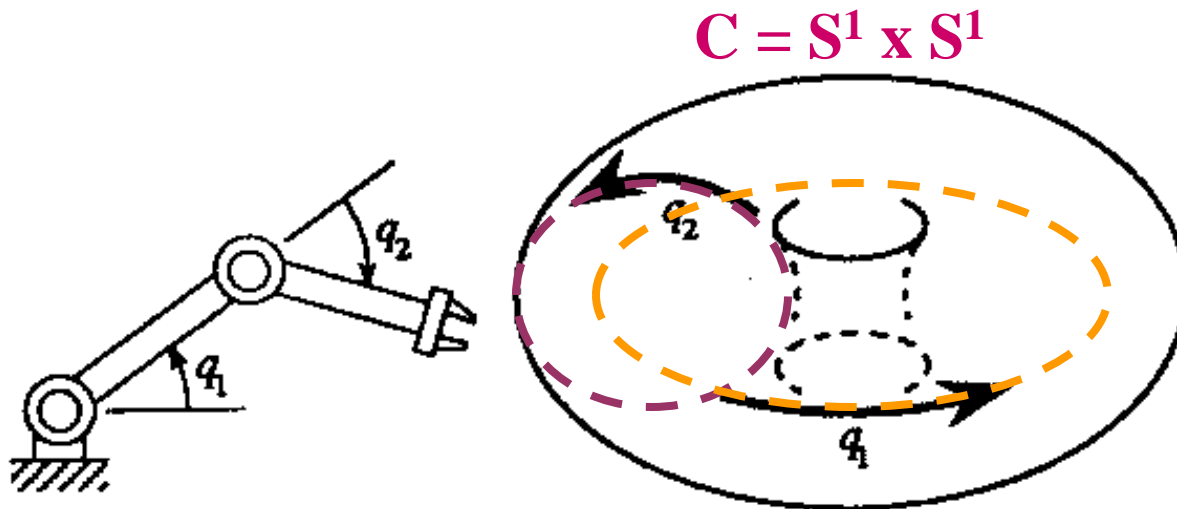

Configuration Space of a Robot

- Space of all its possible configurations
- But the topology of this space is usually not that of a Cartesian space

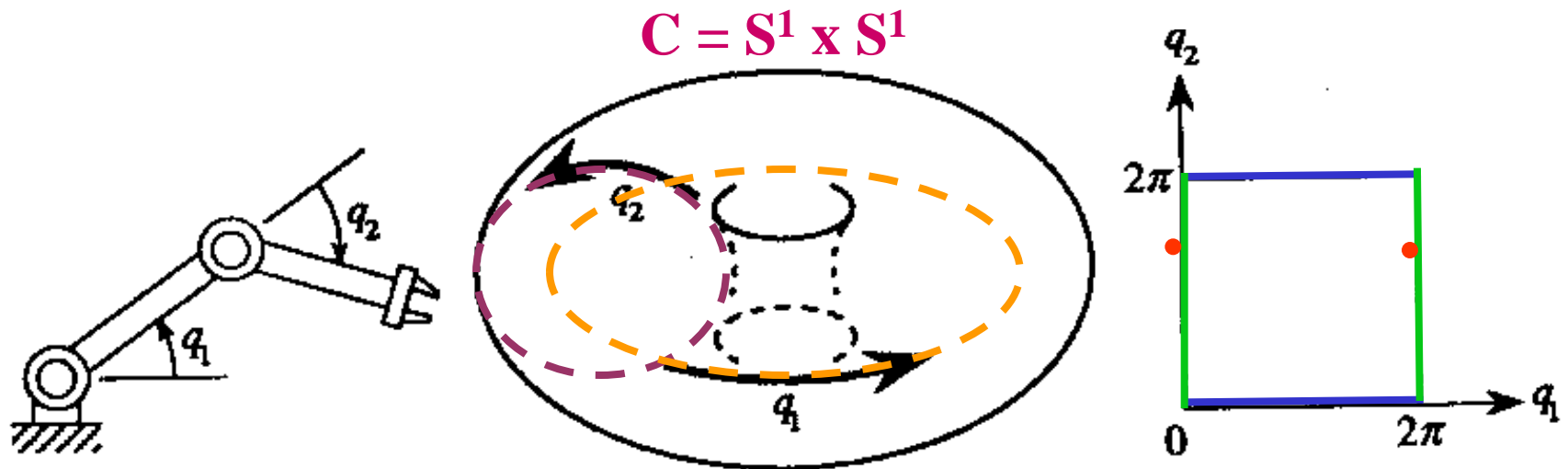

Structure of Configuration Space

- It is a manifold

For each point q , there is a 1-to-1 map between a neighborhood of q and a Cartesian space \mathbf{R}^n , where n is the dimension of C

- This map is a local coordinate system called a chart.

C can always be covered by a finite number of charts. Such a set is called an atlas

Example

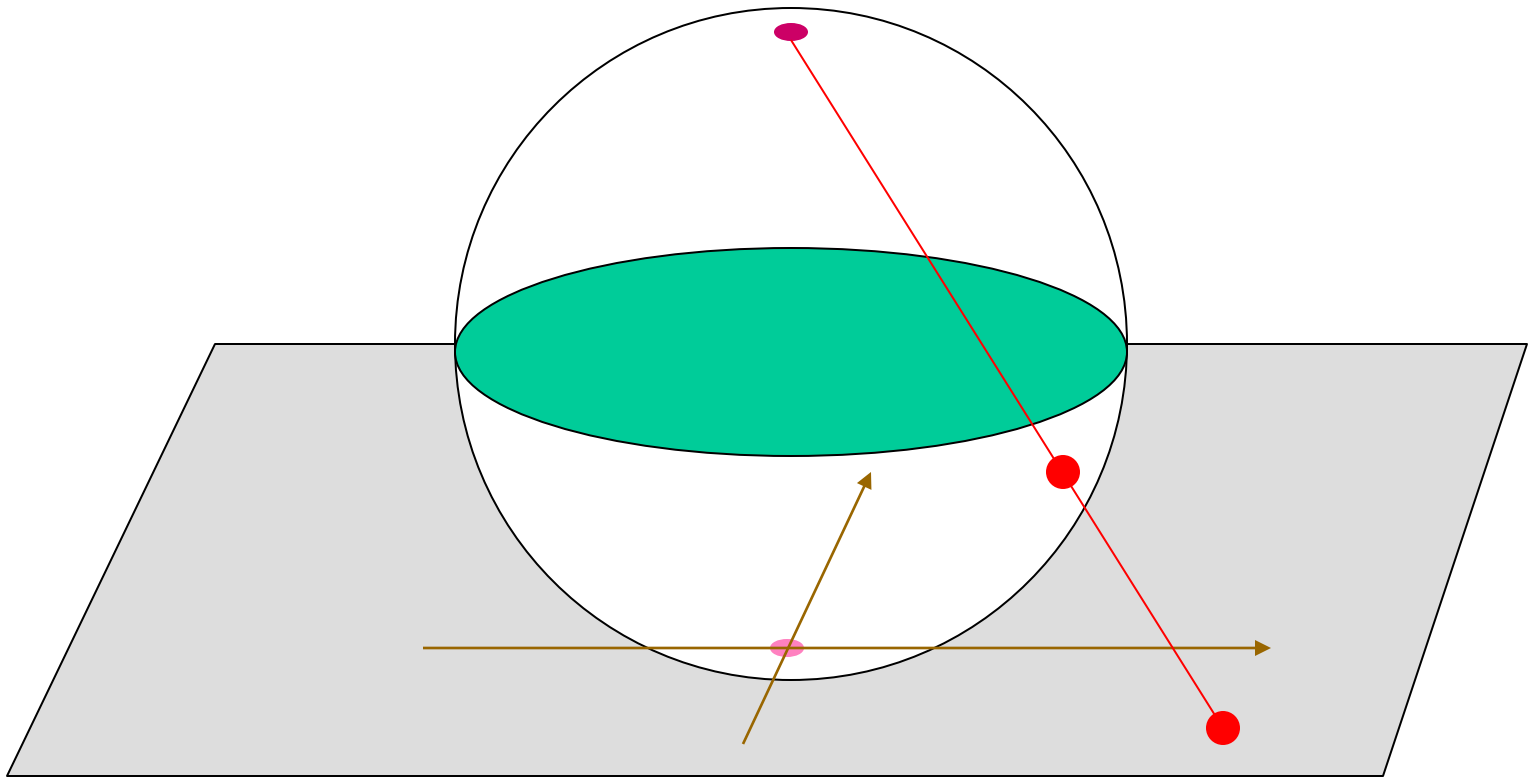

Case of a Planar Rigid Robot

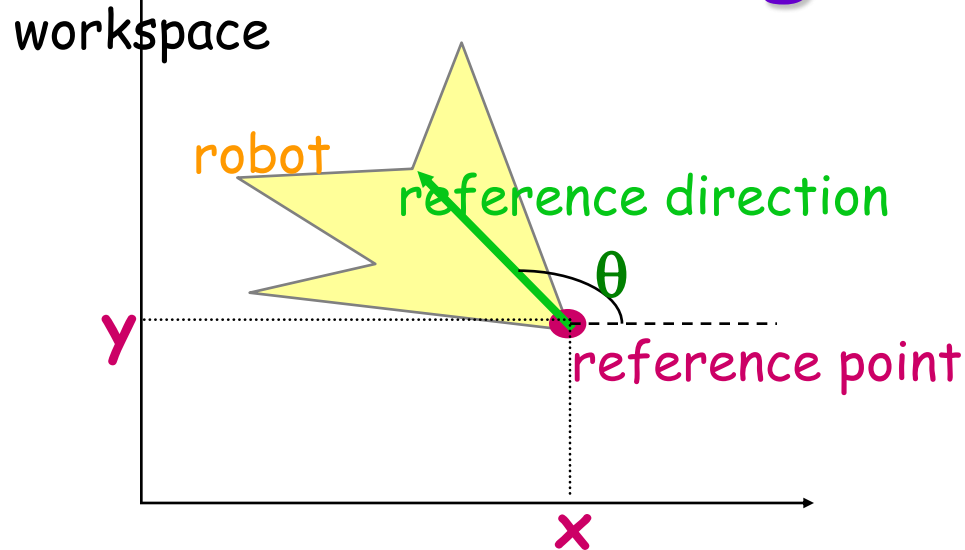

- 3-parameter representation: $q = (x, y, \theta)$ with $\theta \in [0, 2\pi)$. Two charts are needed
- Other representation: $q = (x, y, \cos\theta, \sin\theta)$
→ c-space is a 3-D cylinder $\mathbf{R}^2 \times S^1$
embedded in a 4-D space

Rigid Robot in 3-D Workspace

- $q = (x, y, z, \alpha, \beta, \gamma)$

The c-space is a 6-D space (manifold) embedded in a 12-D Cartesian space. It is denoted by $R^3 \times SO(3)$

- Other representation: $q = (x, y, z, r_{11}, r_{12}, \dots, r_{33})$ where $r_{11}, r_{12}, \dots, r_{33}$ are the elements of rotation matrix R:

$$\begin{pmatrix} r_{11} & r_{12} & r_{13} \\ r_{21} & r_{22} & r_{23} \\ r_{31} & r_{32} & r_{33} \end{pmatrix}$$

with:

- $r_{i1}^2 + r_{i2}^2 + r_{i3}^2 = 1$
- $r_{i1}r_{j1} + r_{i2}r_{j2} + r_{i3}r_{j3} = 0$
- $\det(R) = +1$

Parameterization of $SO(3)$

- Euler angles: (ϕ, θ, ψ)

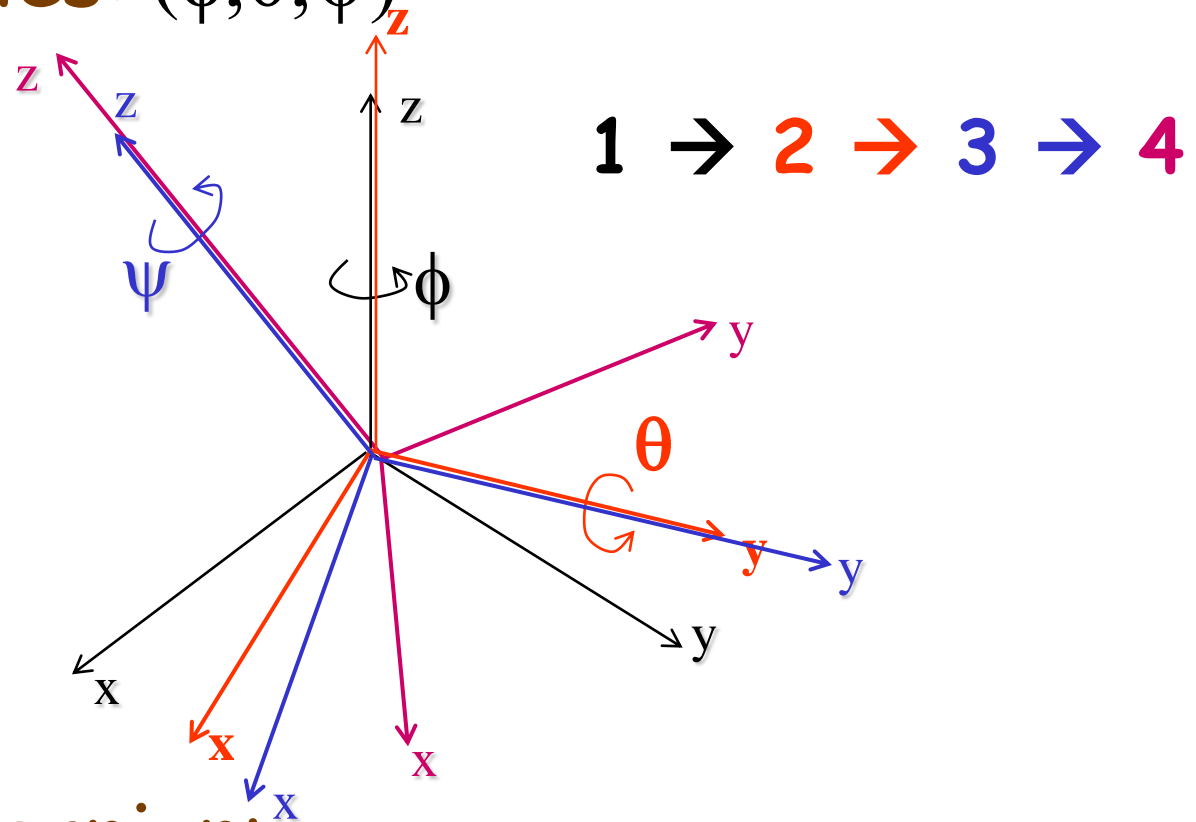

- Unit quaternion:

$$(\cos \theta/2, n_1 \sin \theta/2, n_2 \sin \theta/2, n_3 \sin \theta/2)$$

A welding robot

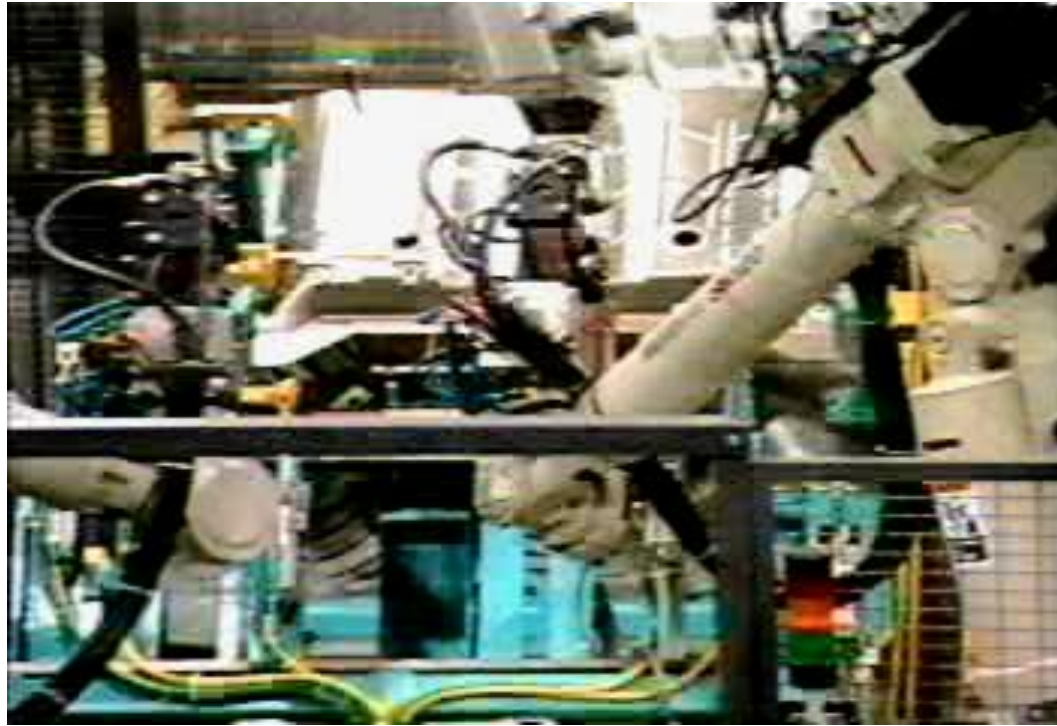

A Stuart Platform

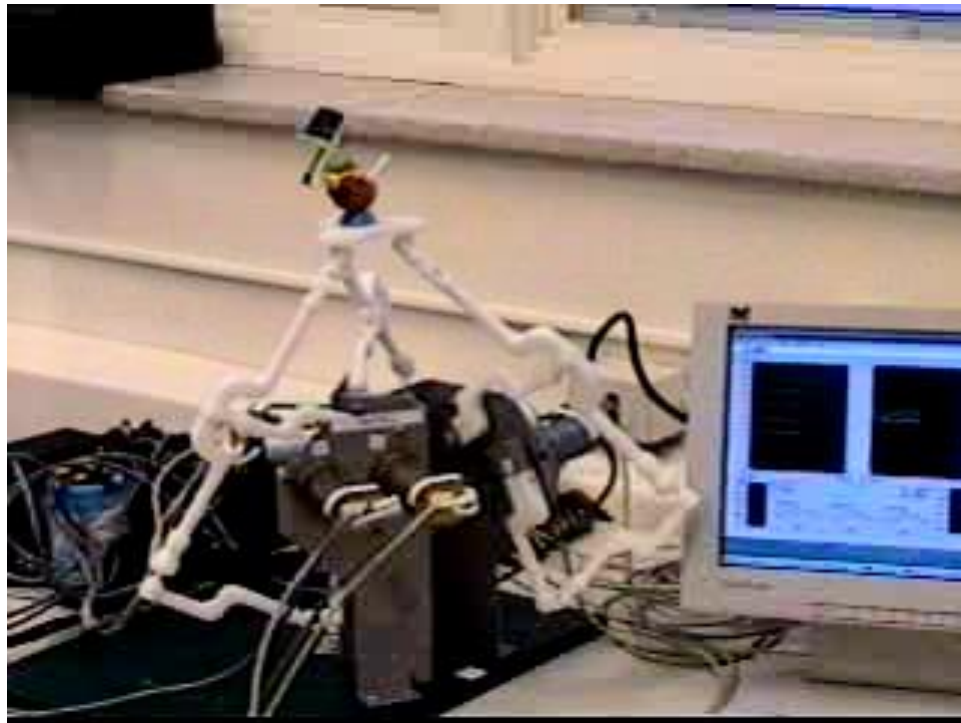

Barrett WAM arm

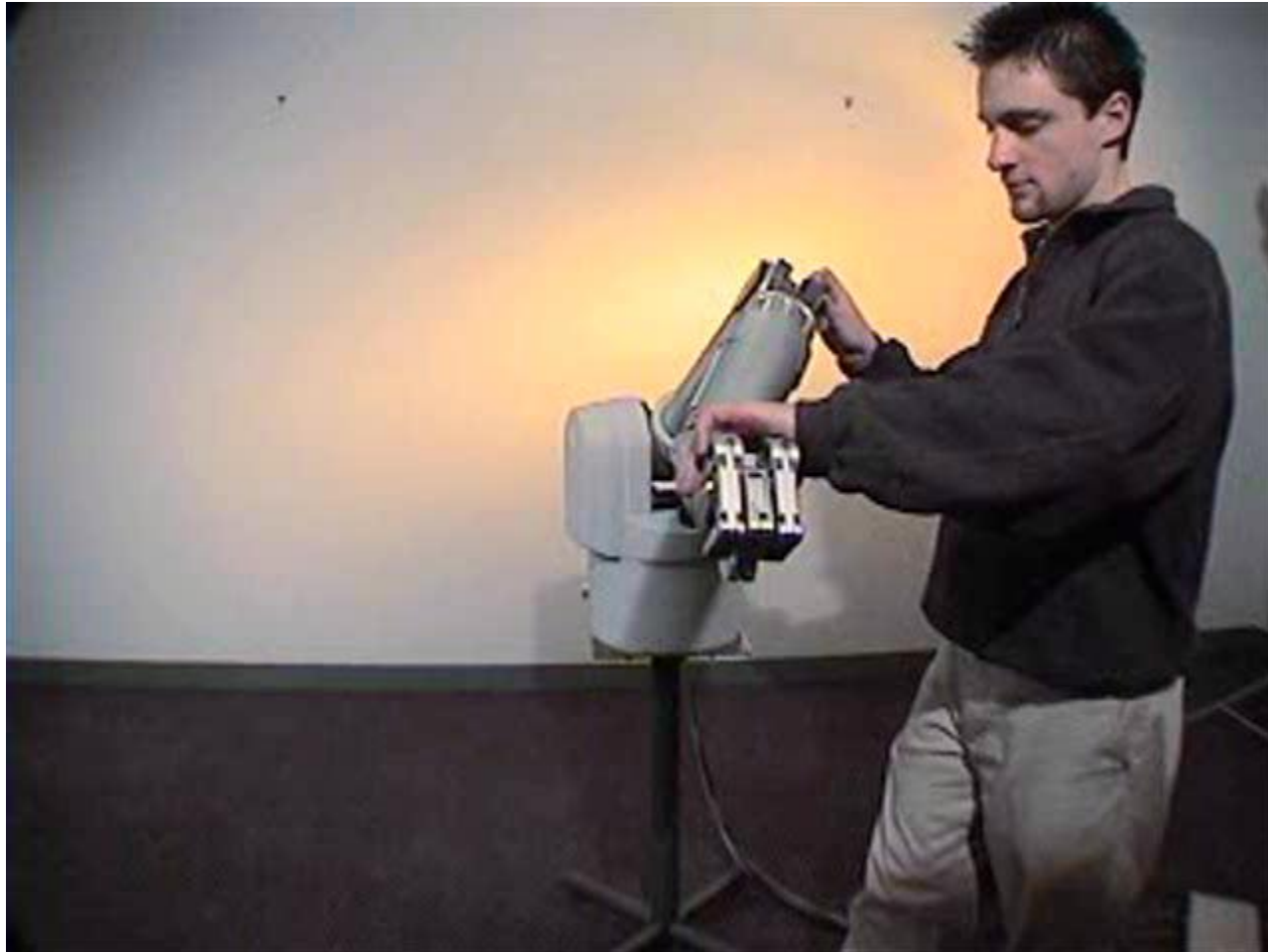

Barrett WAM arm on a mobile platform



Outline

- Assignment 1
- Midterm Monday 20th Oct. 2008
- In class presentations
- Examples of C-Space
- Path Planning in C-Space
 - Probabilistic Roadmaps PRMs
 - Rapidly-exploring Random Trees (RRTs)

Two link path

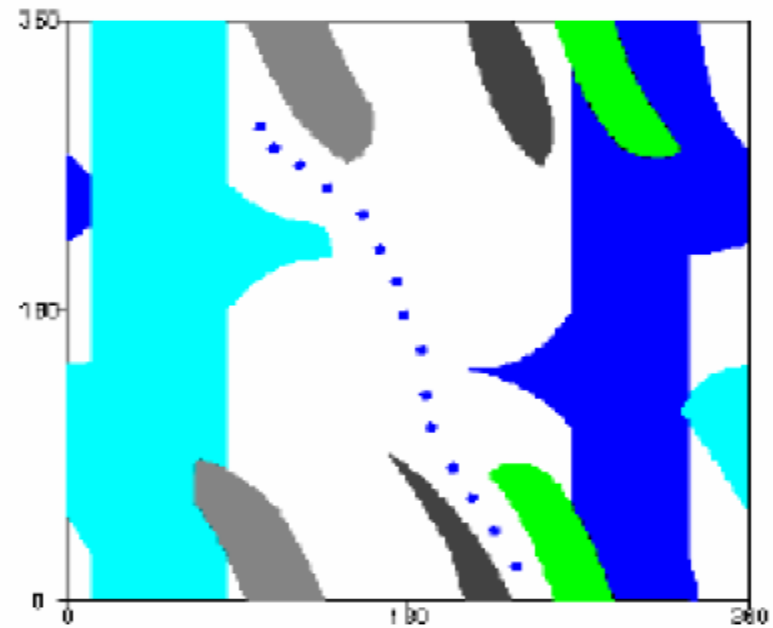
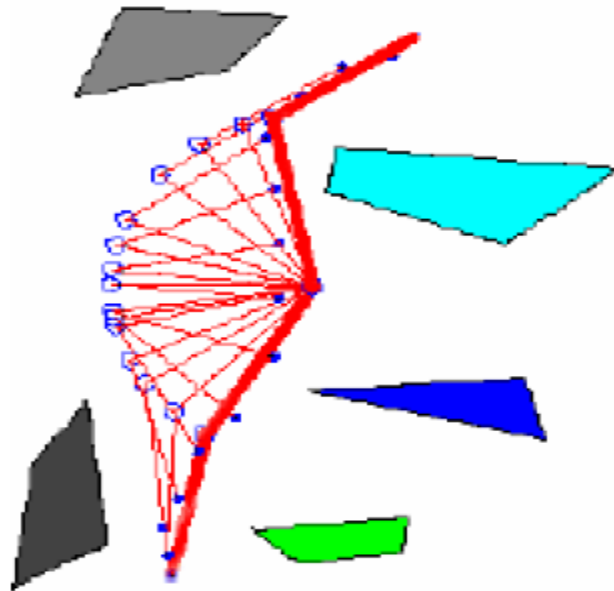

Thanks to Ken Goldberg

2D Rigid Object

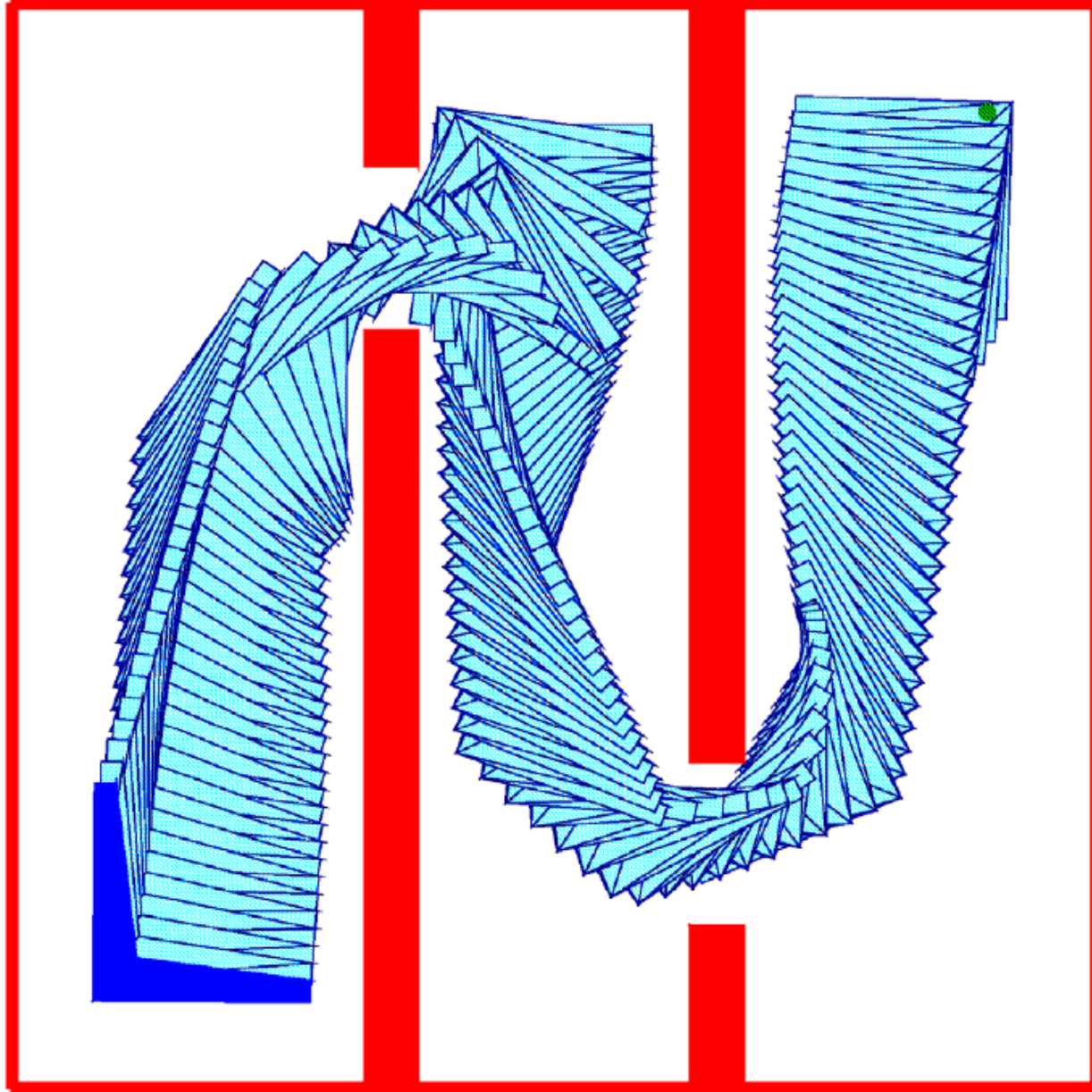

The Configuration Space

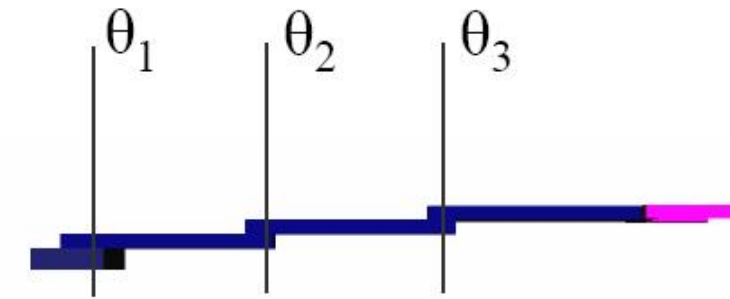

TOP
VIEW



workspace

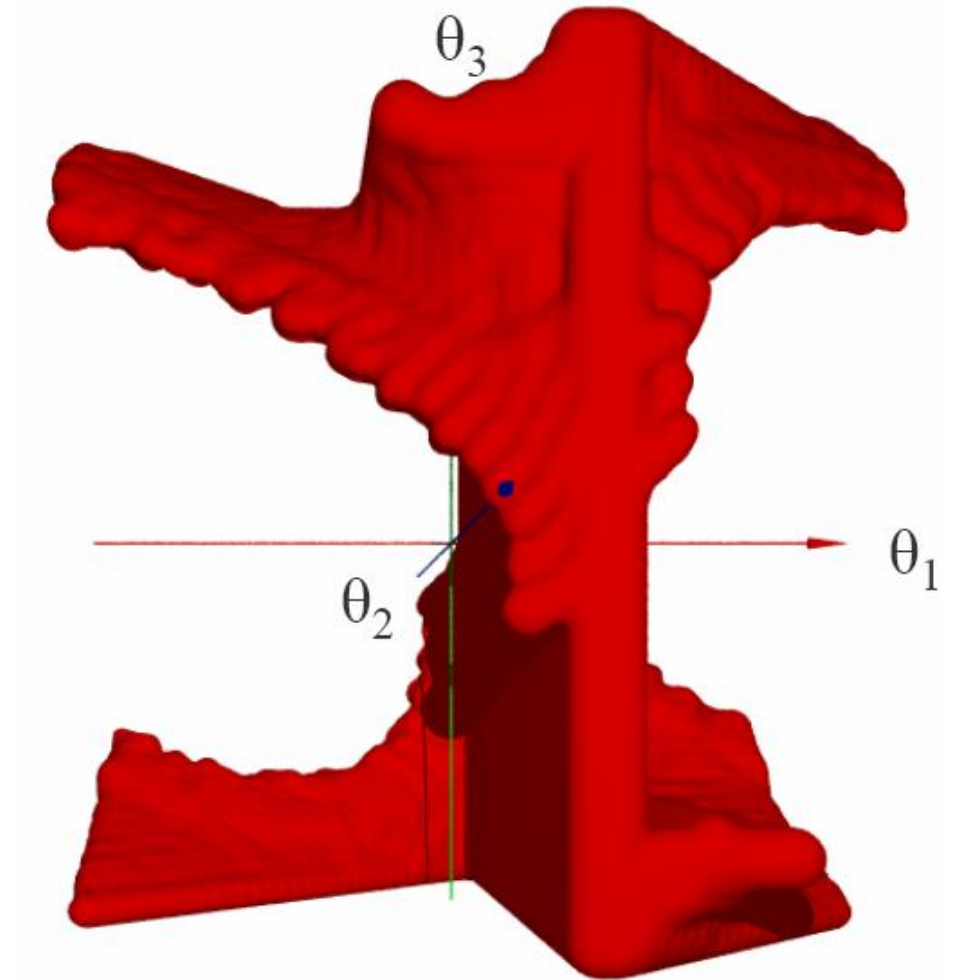

C-space

Moving a piano

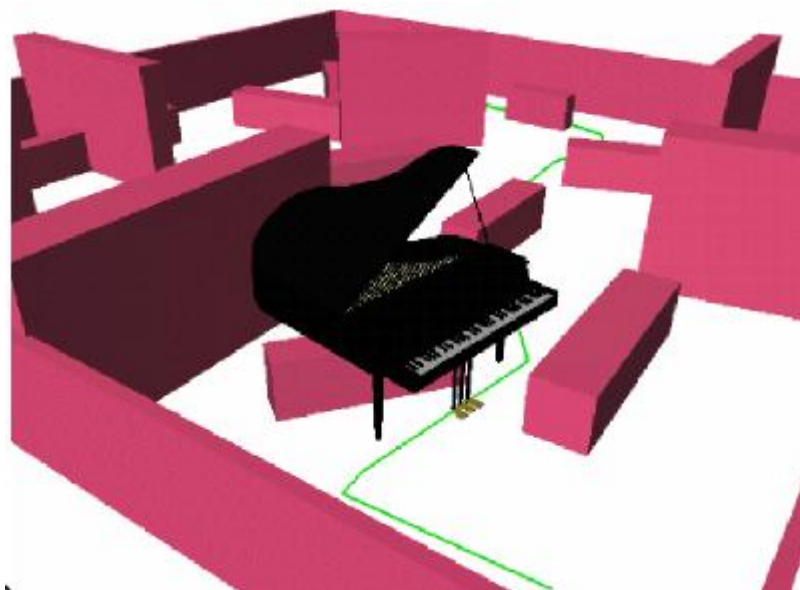
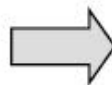

Metric in Configuration Space

A **metric** or **distance** function d in C is a map

$$d: (q_1, q_2) \in C^2 \rightarrow d(q_1, q_2) \geq 0$$

such that:

- $d(q_1, q_2) = 0$ if and only if $q_1 = q_2$
- $d(q_1, q_2) = d(q_2, q_1)$
- $d(q_1, q_2) \leq d(q_1, q_3) + d(q_3, q_2)$

Metric in Configuration Space

Example:

- Robot A and point x of A
- $x(q)$: location of x in the workspace when A is at configuration q
- A distance d in C is defined by:

$$d(q, q') = \max_{x \in A} ||x(q) - x(q')||$$

where $||a - b||$ denotes the Euclidean distance between points a and b in the workspace

Obstacles in C-Space

- A configuration q is **collision-free**, or **free**, if the robot placed at q has null intersection with the obstacles in the workspace
- The **free space** F is the set of free configurations
- A **C-obstacle** is the set of configurations where the robot collides with a given workspace obstacle
- A configuration is **semi-free** if the robot at this configuration touches obstacles without overlap

Disc Robot in 2-D Workspace

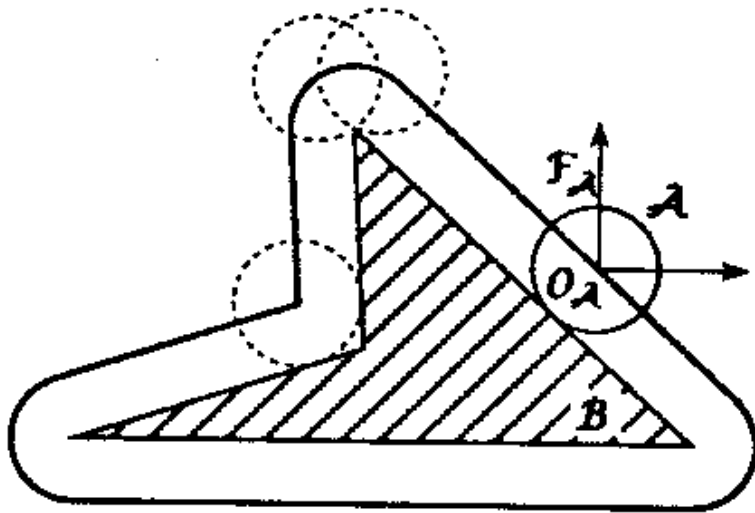

Rigid Robot Translating in 2-D

$$CB = B \ominus A = \{b-a \mid a \in A, b \in B\}$$

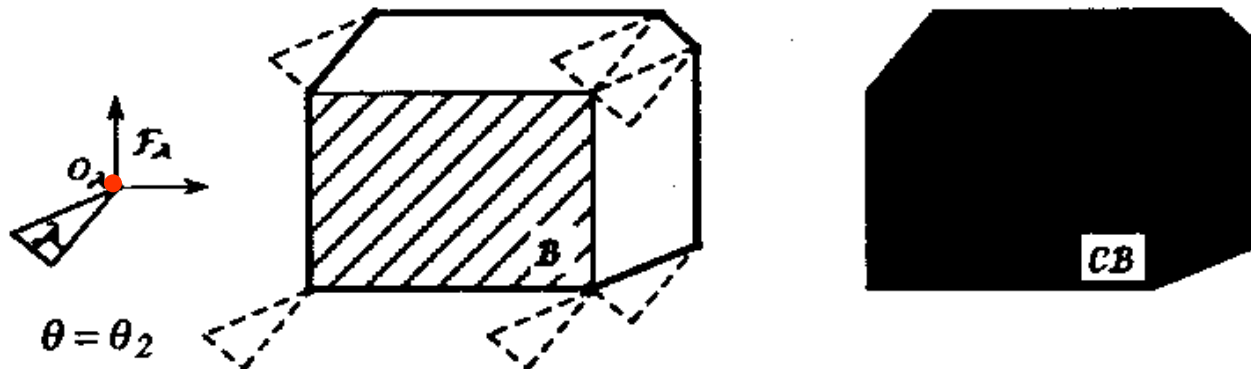
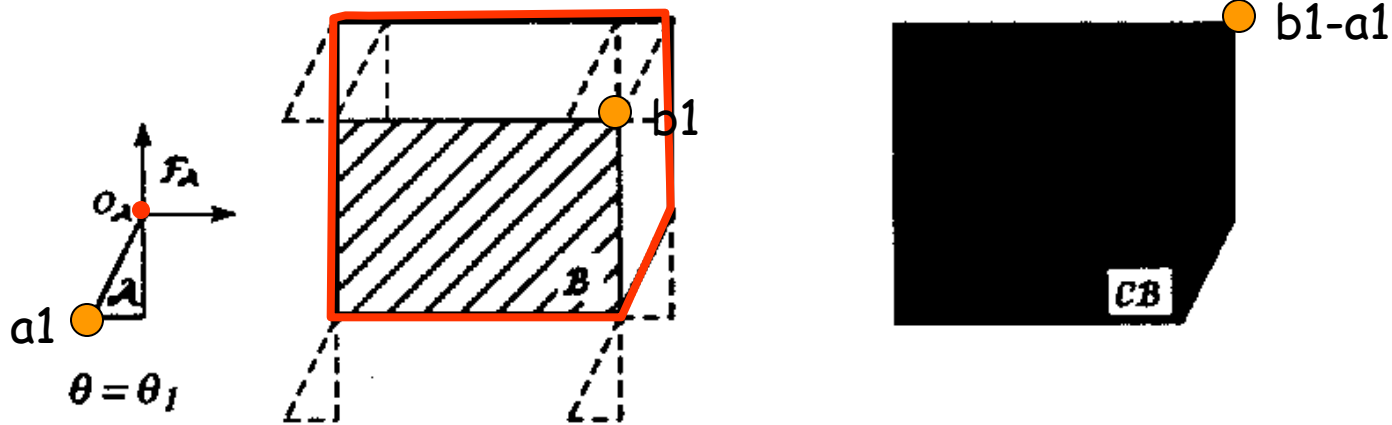

Linear-Time Computation of C-Obstacle in 2-D

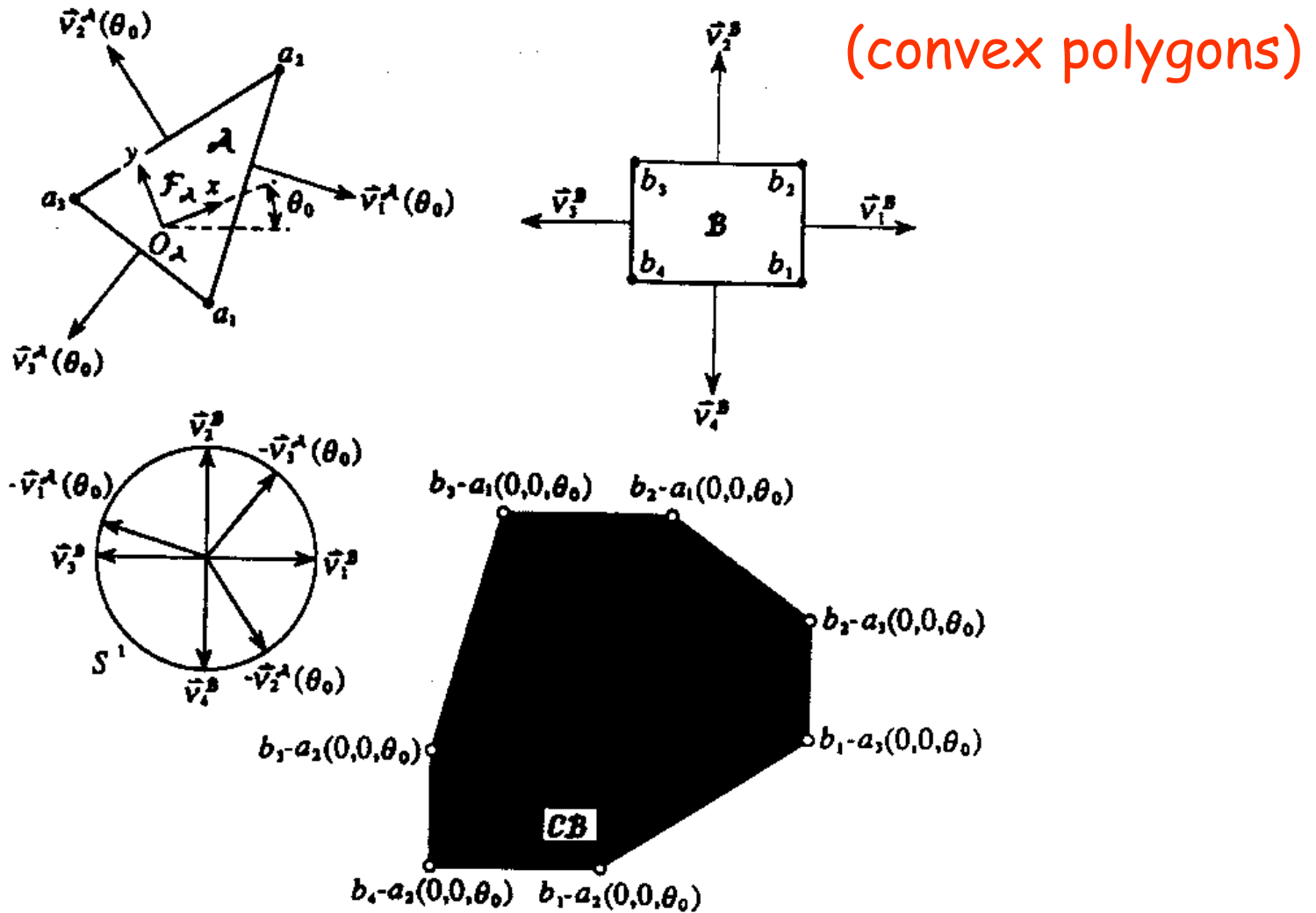

Rigid Robot Translating and Rotating in 2-D

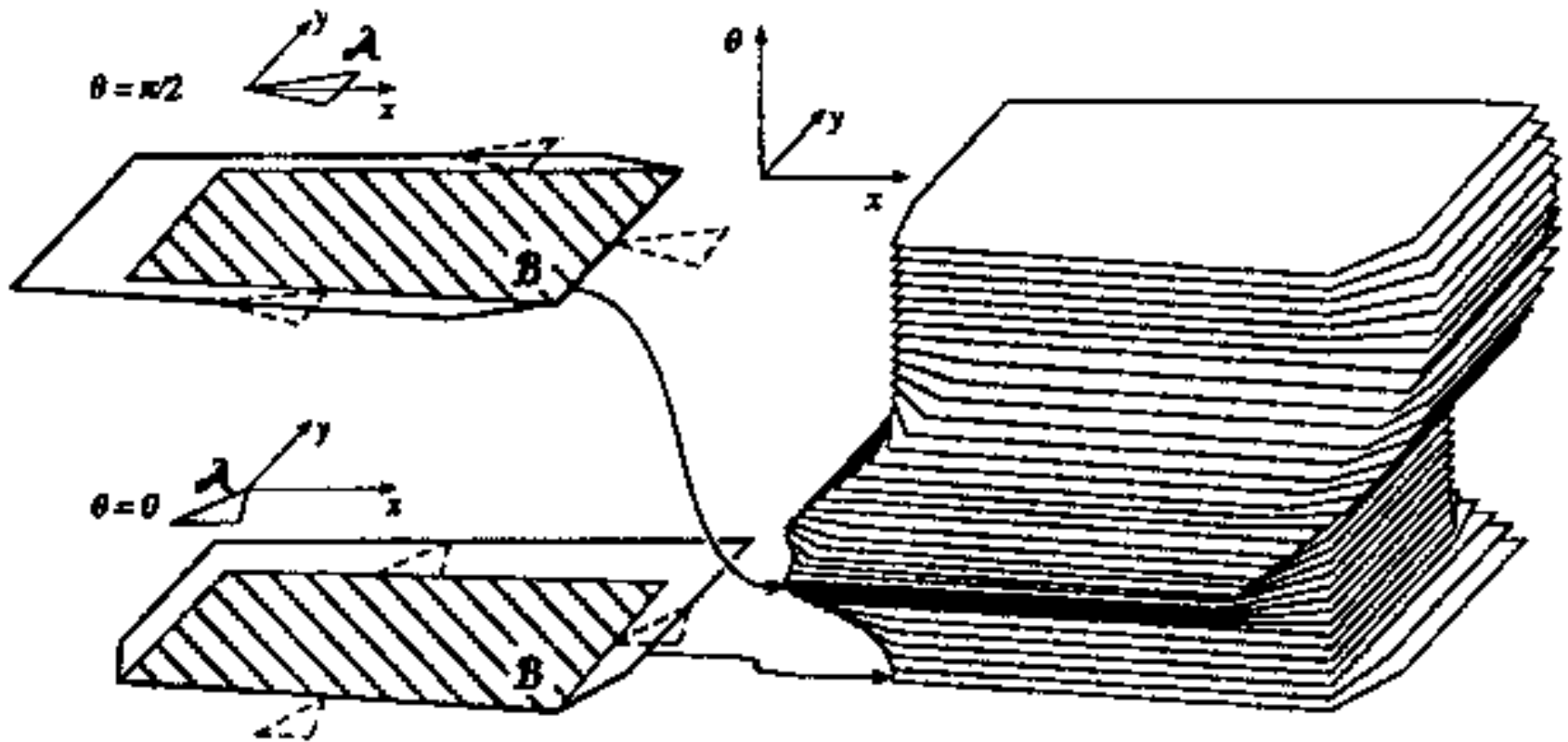

Free and Semi-Free Paths

- A **free path** lies entirely in the free space F
- A **semi-free path** lies entirely in the semi-free space

Remarks on Free-Space Topology

- The robot and the obstacles are modeled as **closed** subsets, meaning that they contain their boundaries
- One can show that the C -obstacles are closed subsets of the configuration space C as well
- Consequently, **the free space F is an open subset of C . Hence, each free configuration is the center of a ball of non-zero radius entirely contained in F**
- The semi-free space is a closed subset of C . Its boundary is a superset of the boundary of F

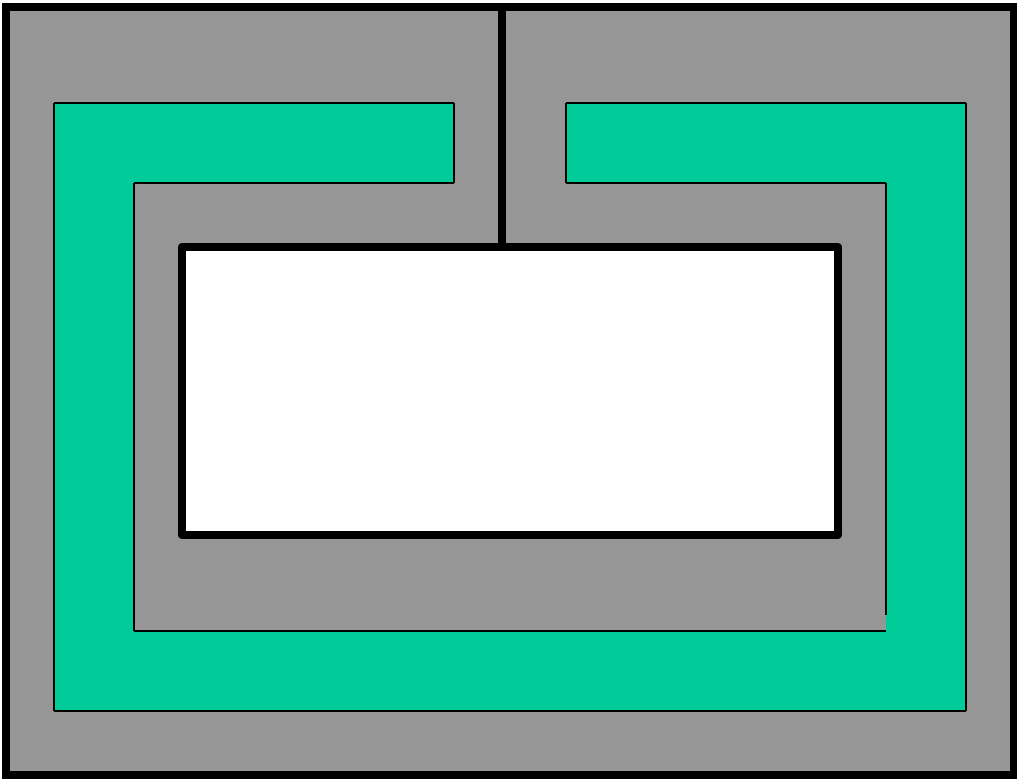
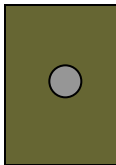

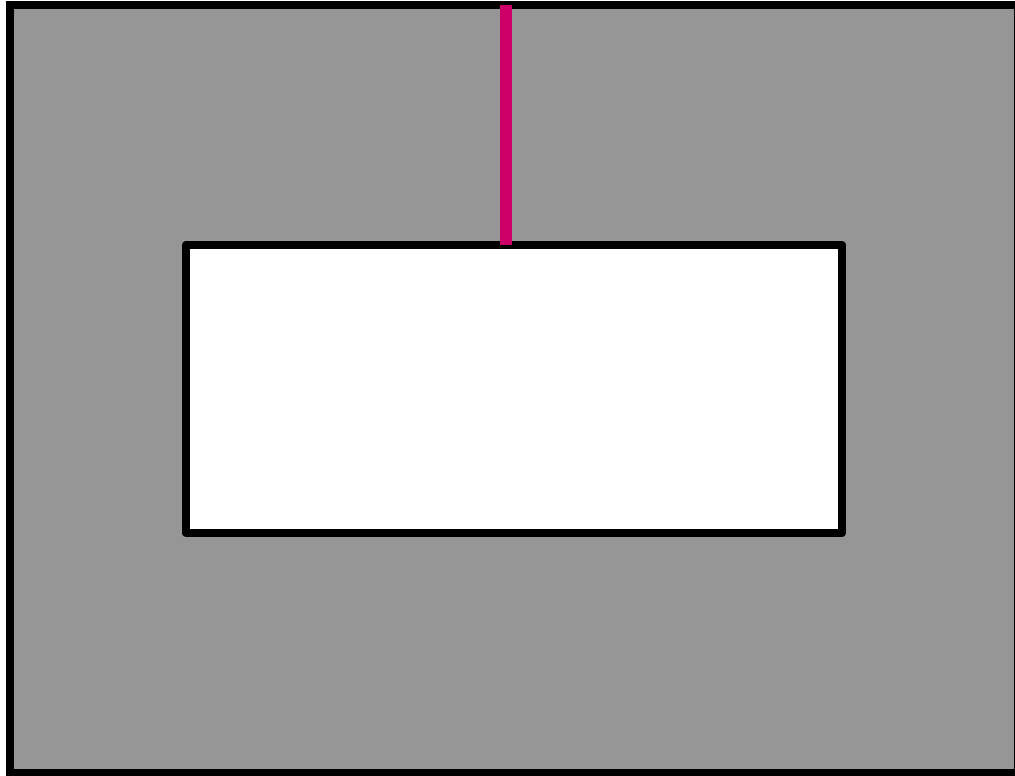

Notion of Homotopic Paths

- Two paths with the same endpoints are **homotopic** if one can be continuously deformed into the other

- $\mathbb{R} \times S^1$ example:

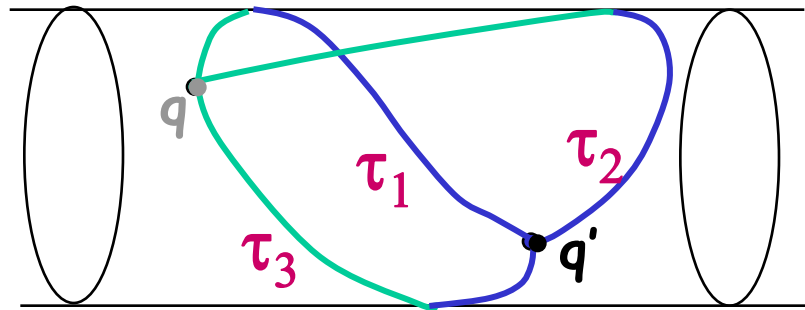

- τ_1 and τ_2 are homotopic
- τ_1 and τ_3 are not homotopic
- In this example, infinity of **homotopy classes**

Connectedness of C -Space

- C is **connected** if every two configurations can be connected by a path
- C is **simply-connected** if any two paths connecting the same endpoints are homotopic
Examples: \mathbf{R}^2 or \mathbf{R}^3
- Otherwise C is **multiply-connected**
Examples: S^1 and $SO(3)$ are multiply-connected:
 - In S^1 , infinity of homotopy classes
 - In $SO(3)$, only two homotopy classes

Classes of Homotopic Free Paths

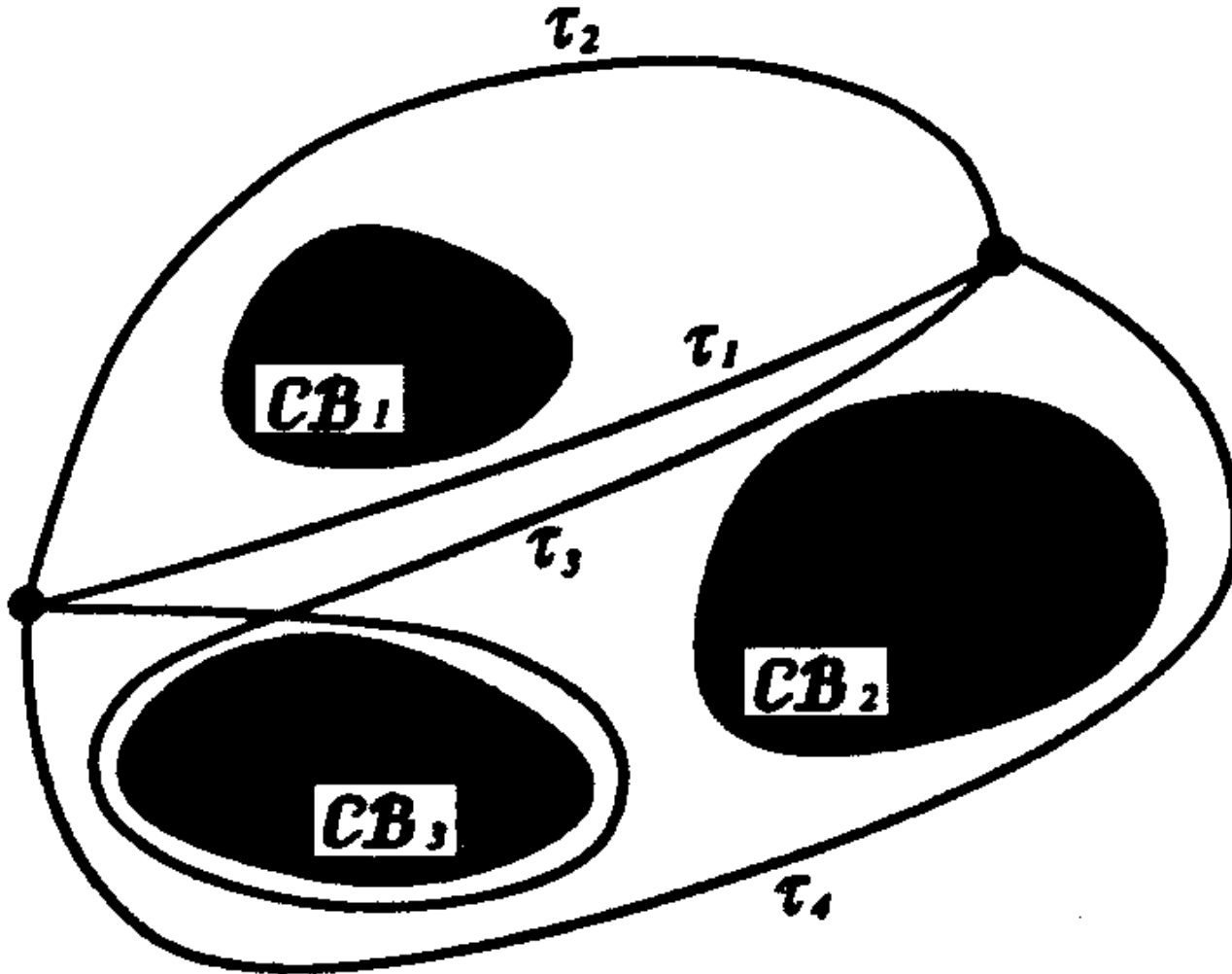

Probabilistic Roadmaps PRMs

Rapidly-exploring Random Trees

- A point P in C is randomly chosen.
- The nearest vertex in the RRT is selected.
- A new edge is added from this vertex in the direction of P , at distance ϵ .
- The further the algorithm goes, the more space is covered.

Rapidly-expanding Random Trees

- Starting vertex

Rapidly-expanding Random Trees



Vertex randomly drawn



Rapidly-expanding Random Trees



Nearest vertex

Rapidly-expanding Random Trees

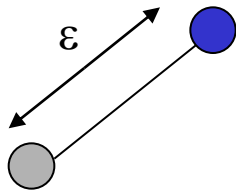

New vertex

The vertex is in C_{free}

Rapidly-expanding Random Trees

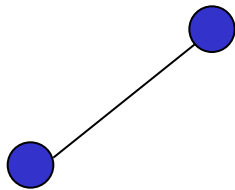

Vertex randomly drawn



Rapidly-expanding Random Trees



Rapidly-expanding Random Trees



Rapidly-expanding Random Trees

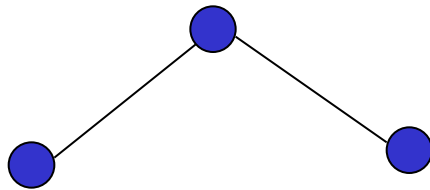

Rapidly-expanding Random Trees

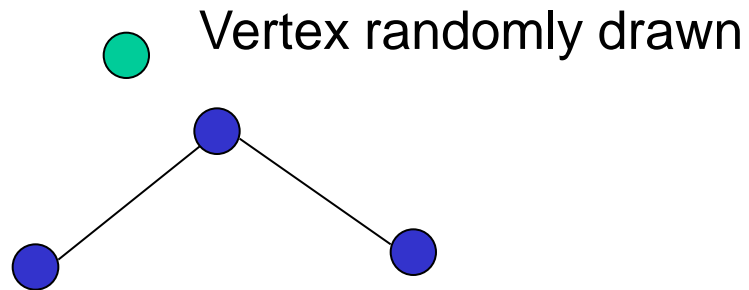

Rapidly-expanding Random Trees

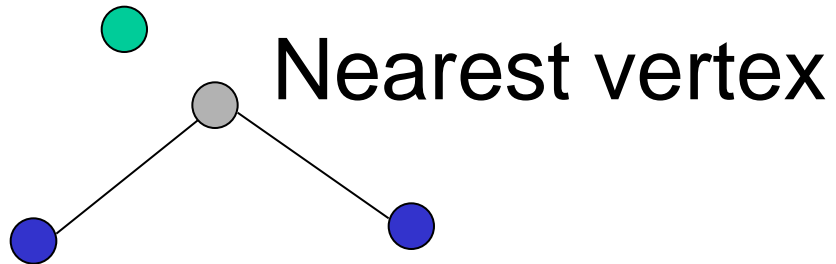

Rapidly-expanding Random Trees

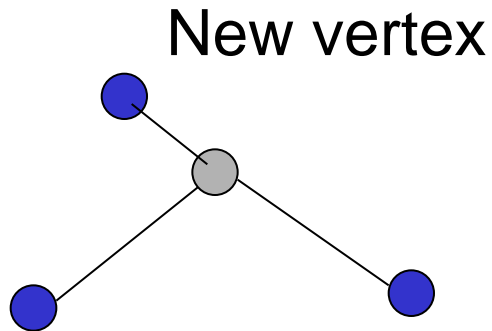

Rapidly-expanding Random Trees

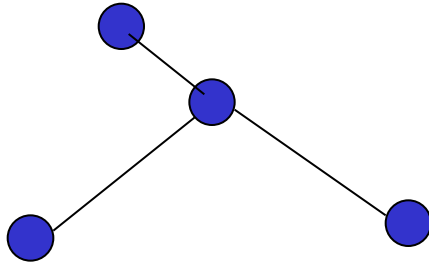

And it continues...

RRT-Connect

- We grow two trees, one from the beginning vertex and another from the end vertex
- Each time we create a new vertex, we try to greedily connect the two trees

RRT-Connect: example

● Start



● Goal

RRT-Connect: example



Random vertex



RRT-Connect: example

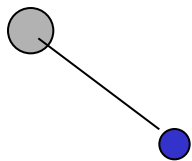

RRT-Connect: example

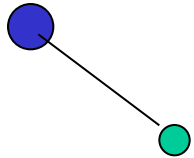

We greedily connect the
bottom tree to our new
vertex



RRT-Connect: example

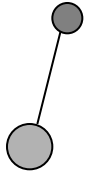
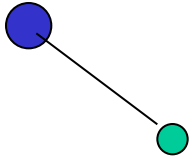

RRT-Connect: example

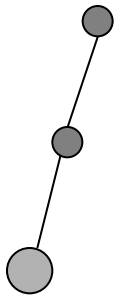
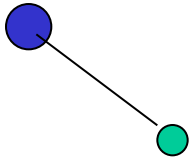

RRT-Connect: example

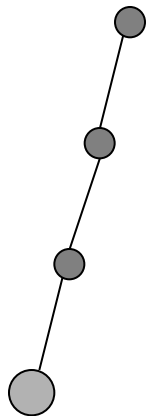
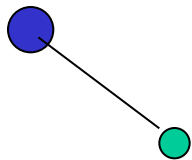

RRT-Connect: example

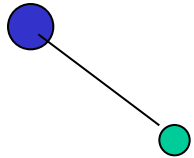

Obstacle found !

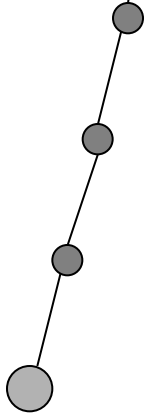

RRT-Connect: example

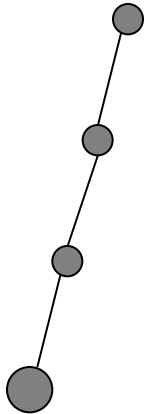
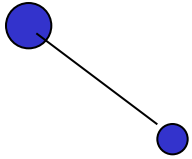

Now we swap roles !

RRT-Connect: example

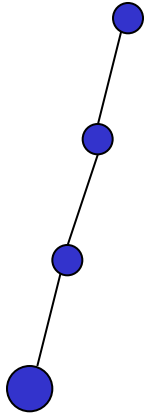
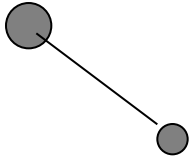

Now we swap roles !

RRT-Connect: example

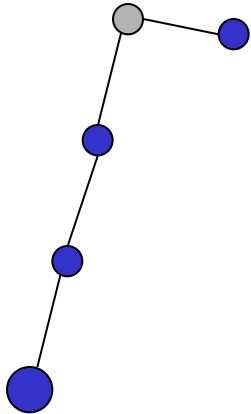
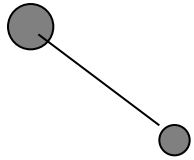

We grow the bottom tree

RRT-Connect: example

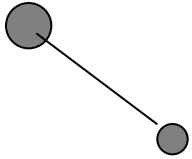

Now we greedily try to connect

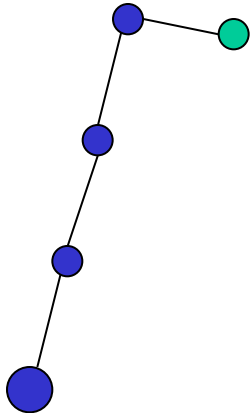

And we continue...

RRT-Connect: example

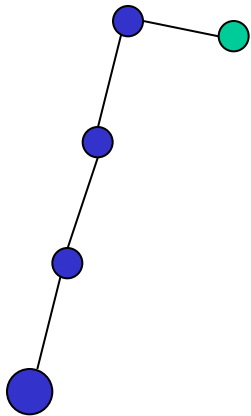
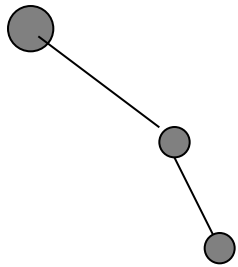

RRT-Connect: example

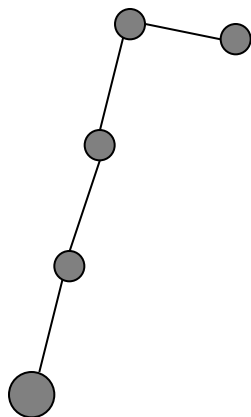
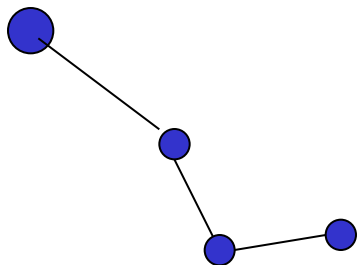

RRT-Connect: example

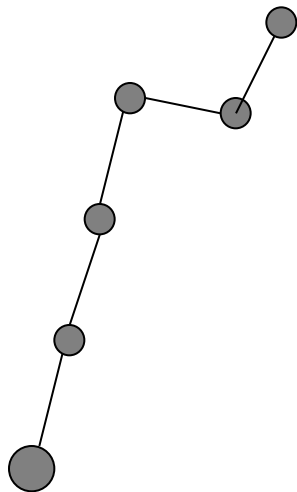
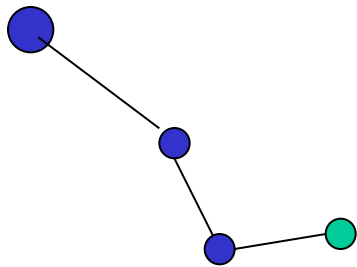

RRT-Connect: example

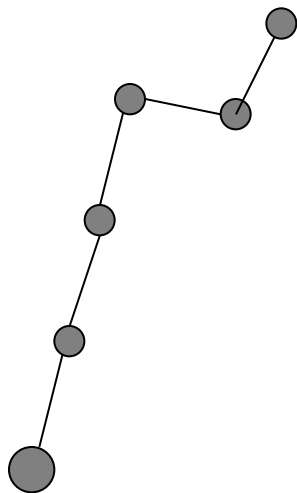
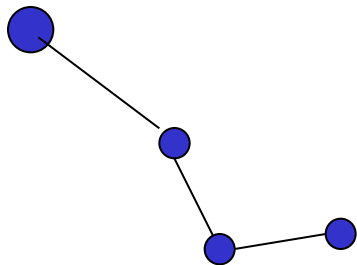

RRT-Connect: example

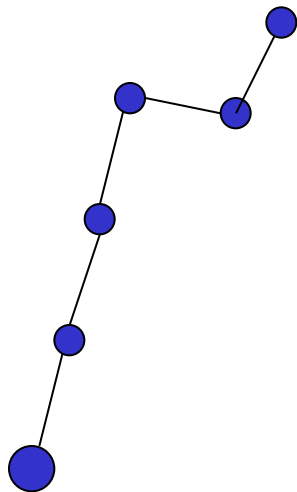
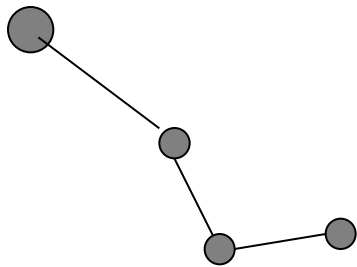

RRT-Connect: example

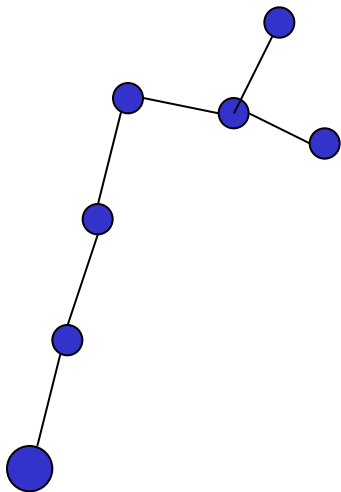
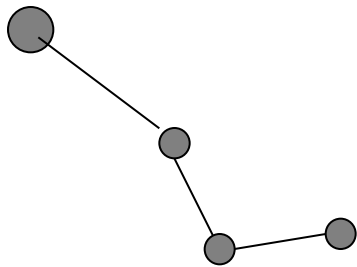

RRT-Connect: example

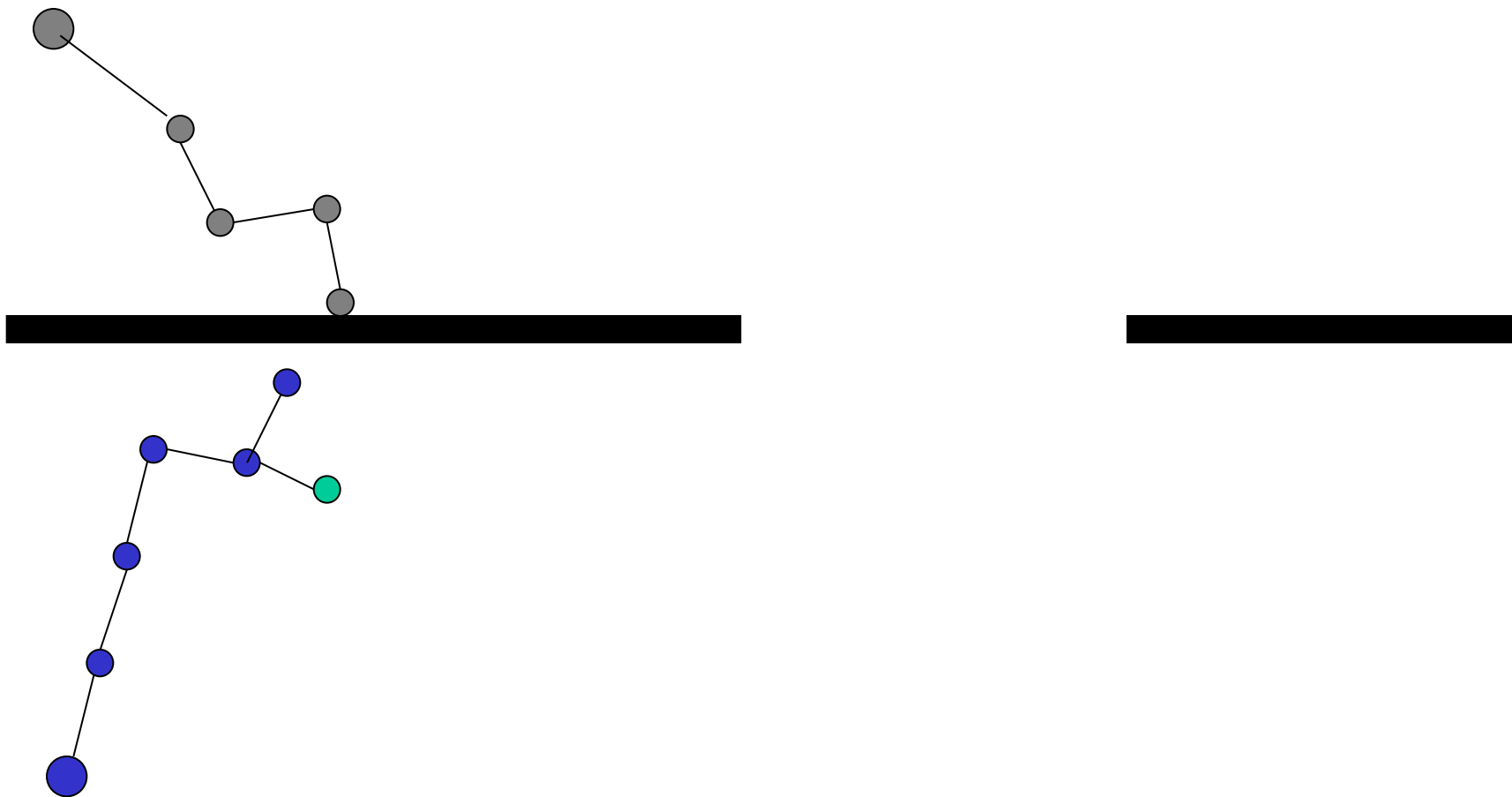

RRT-Connect: example

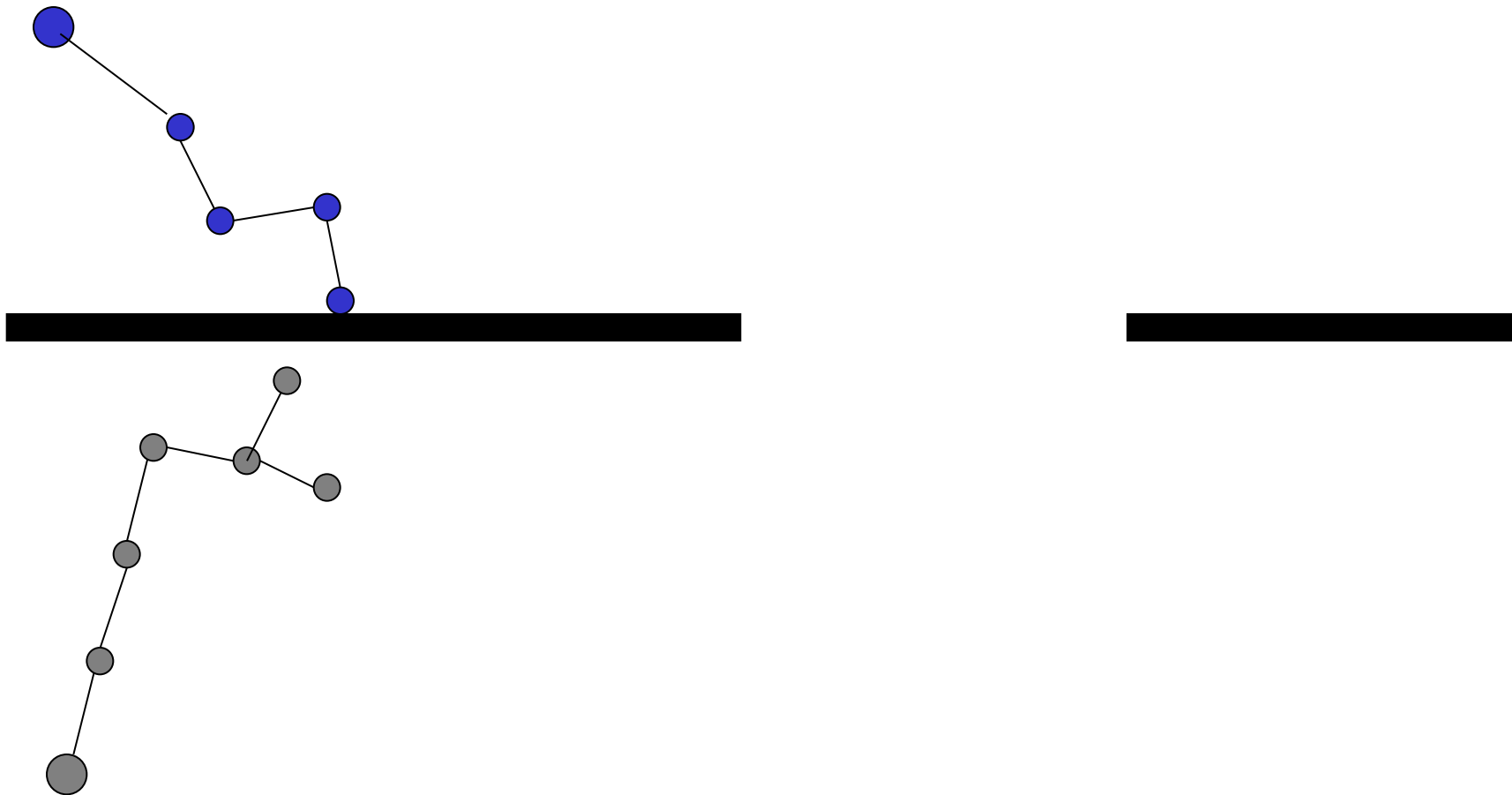

RRT-Connect: example

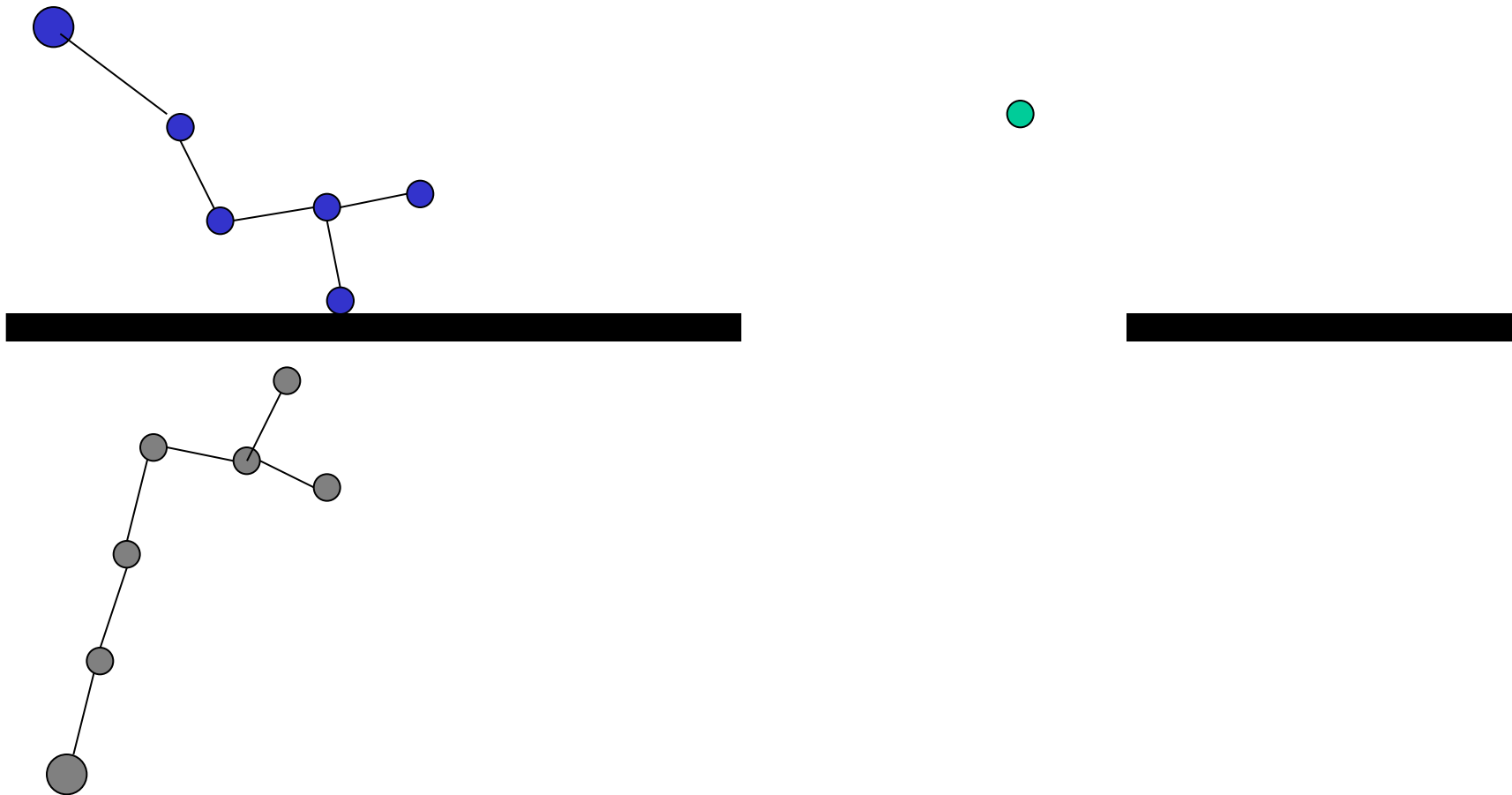

RRT-Connect: example

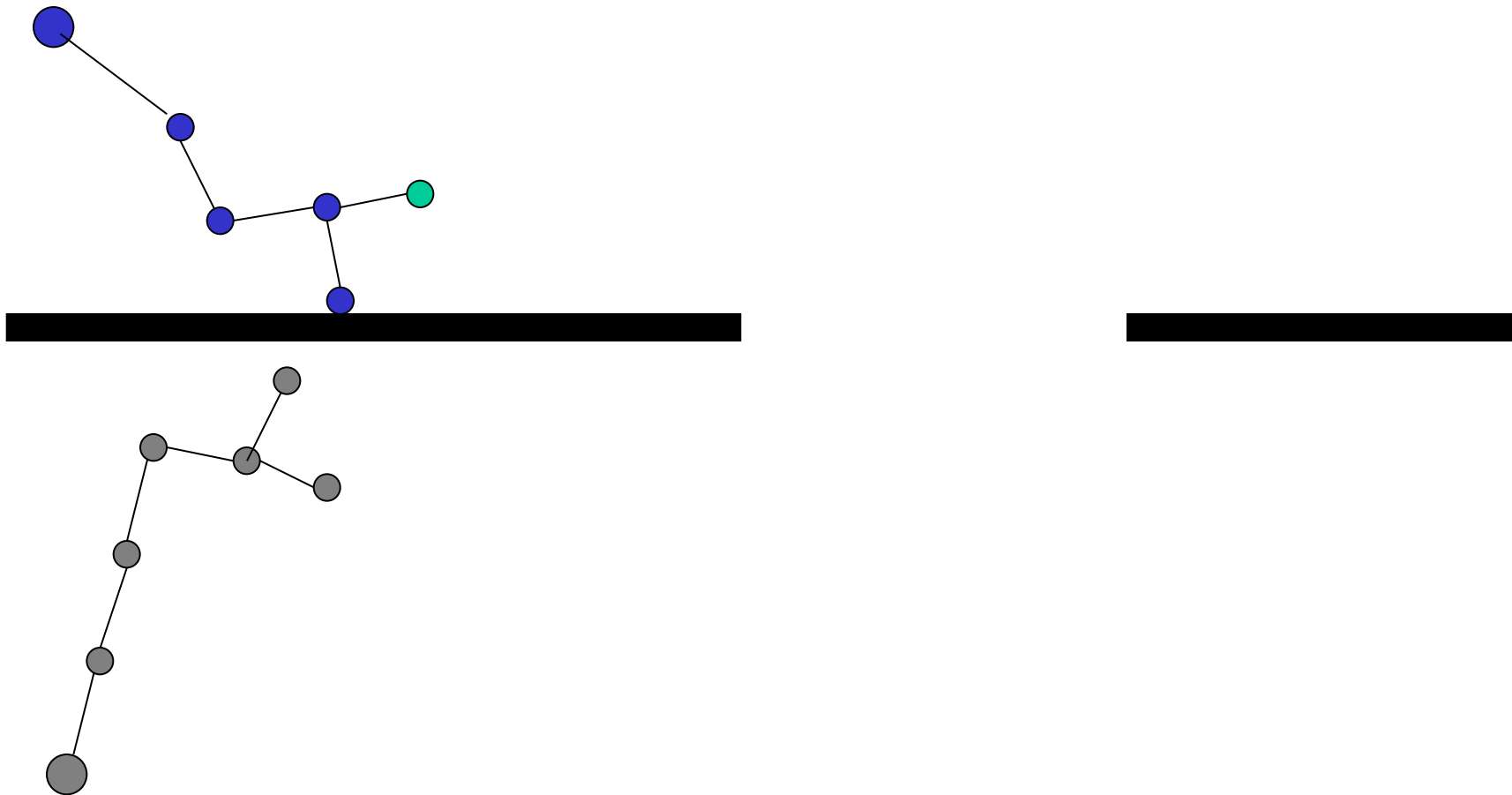

RRT-Connect: example

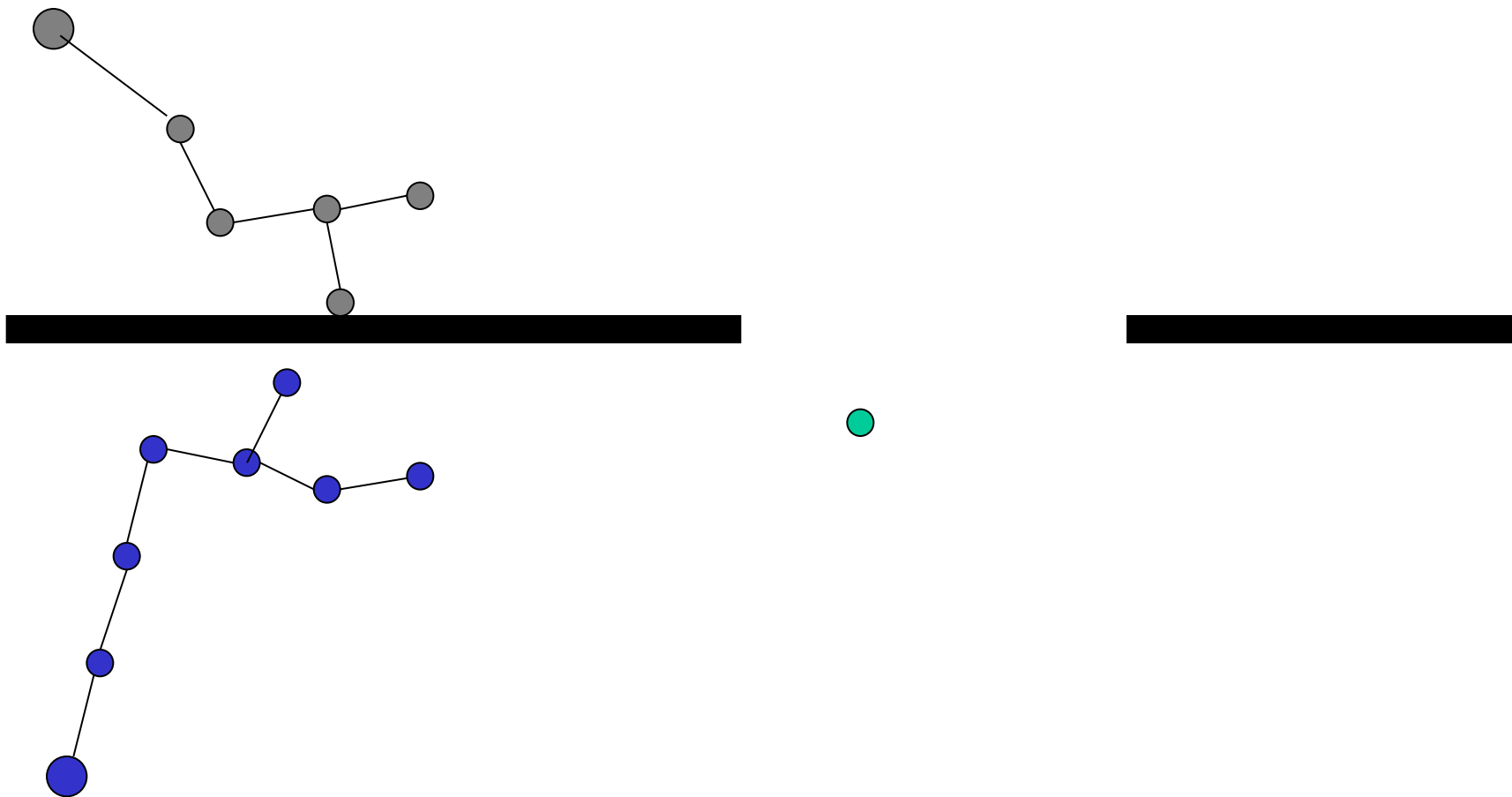

RRT-Connect: example

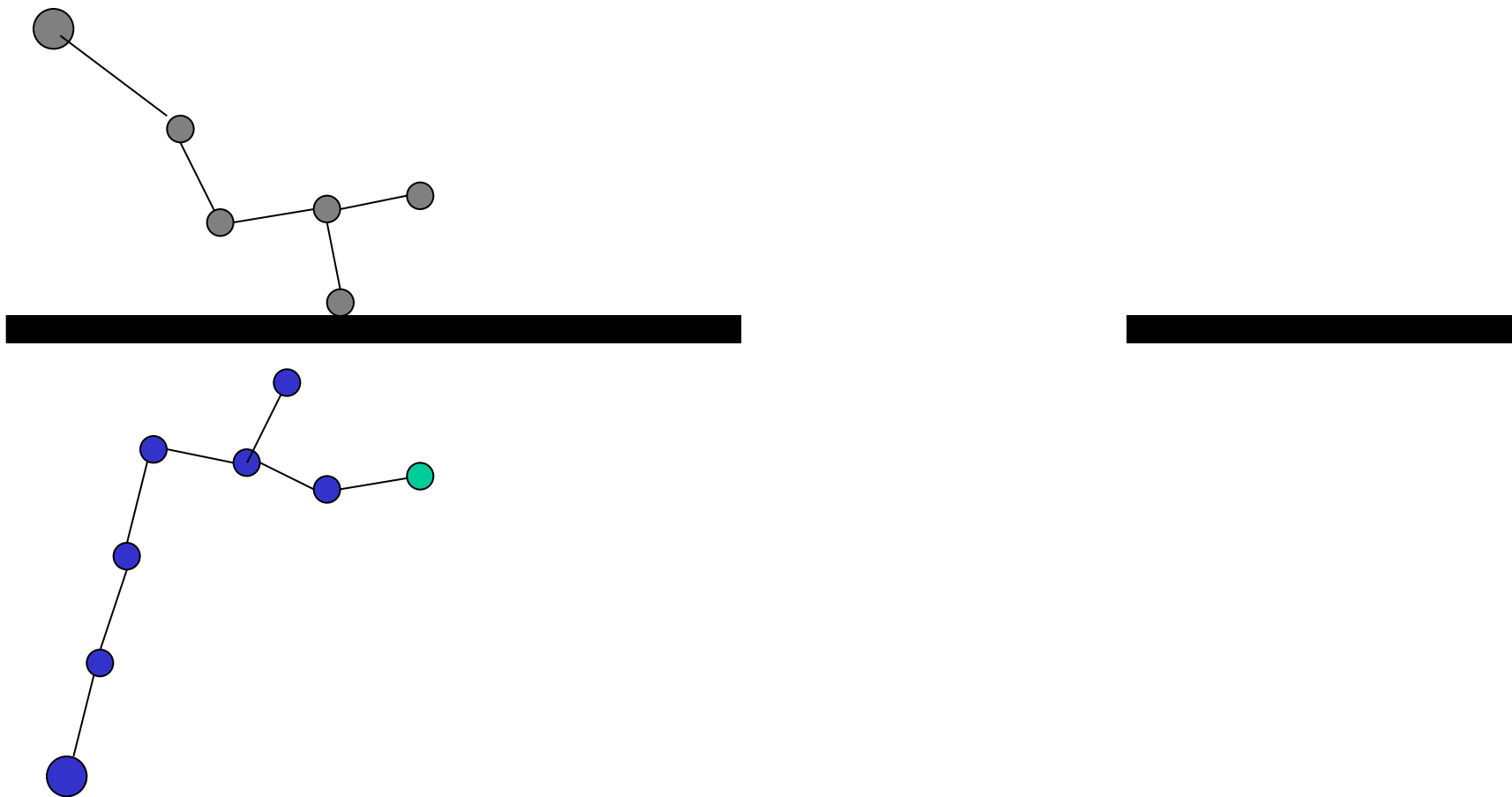

RRT-Connect: example

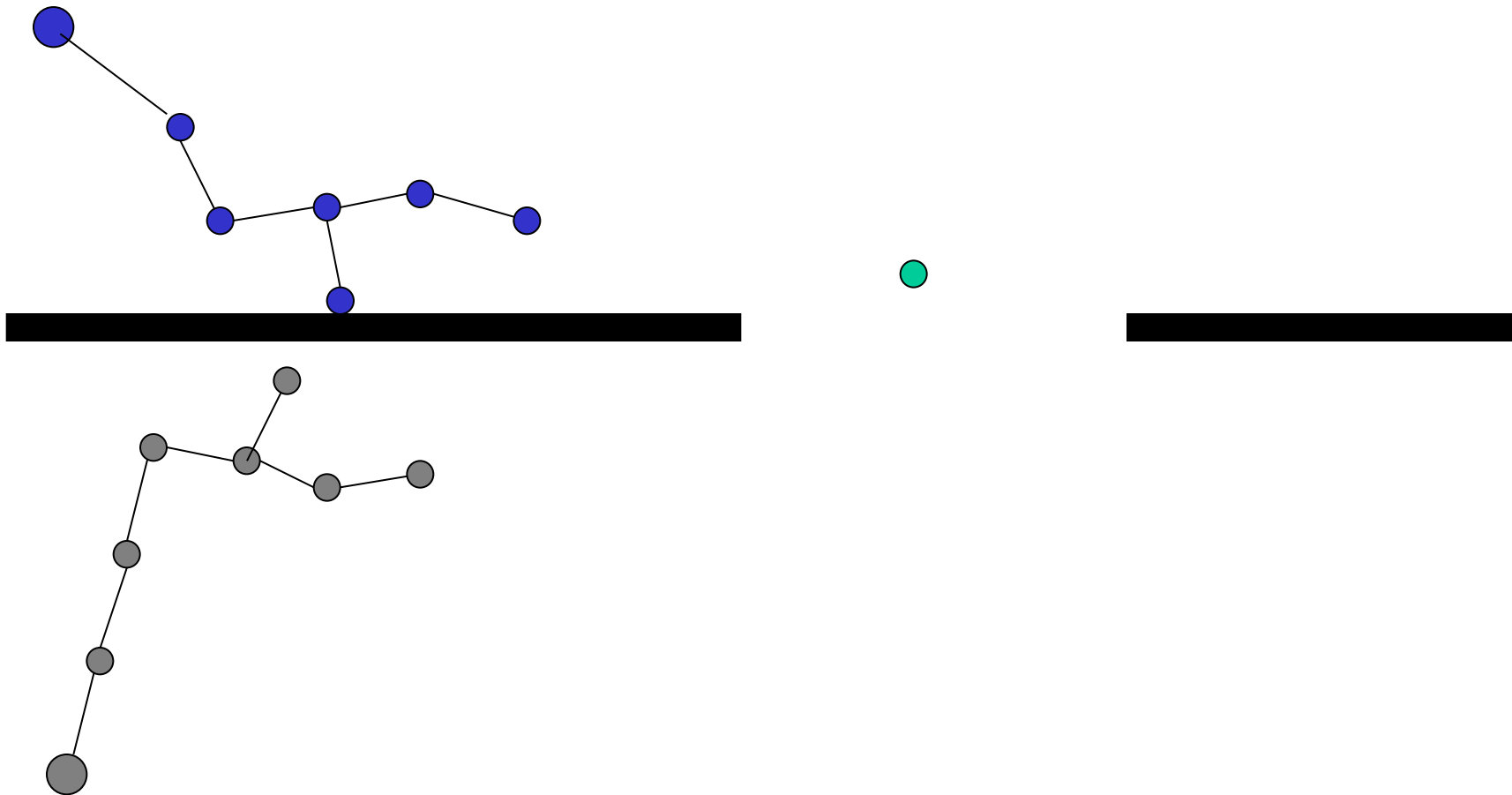

RRT-Connect: example

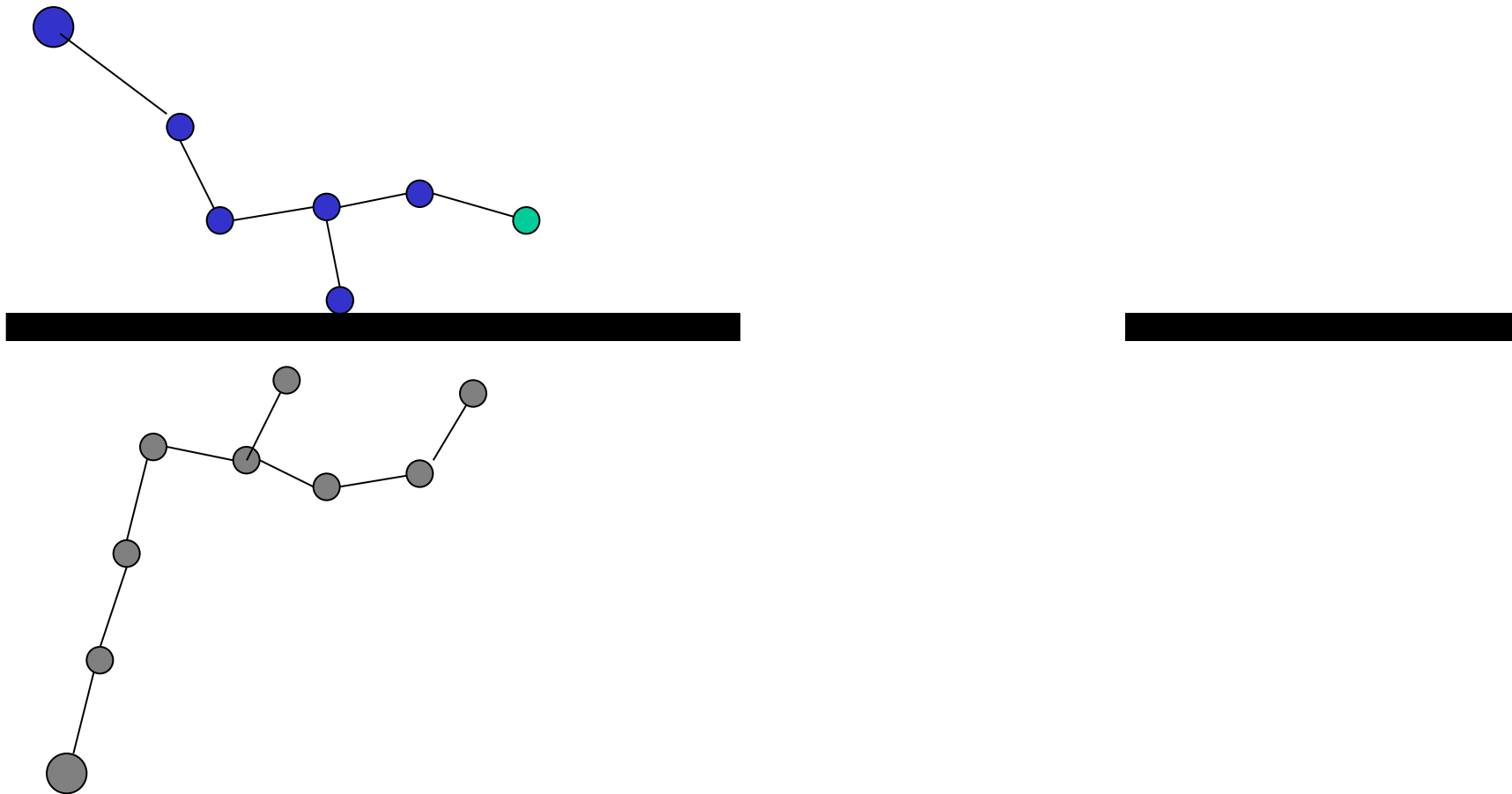

RRT-Connect: example

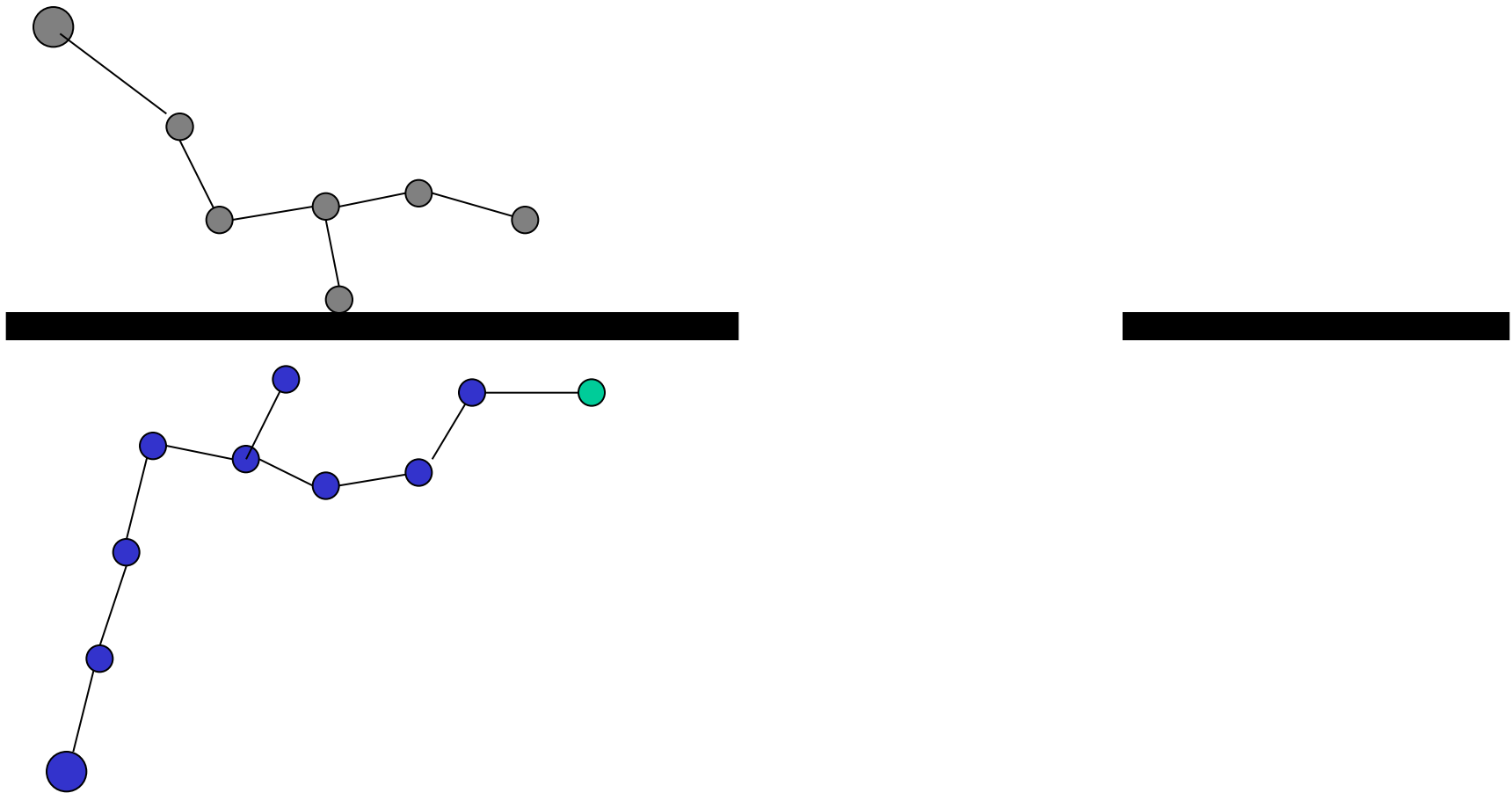

RRT-Connect: example

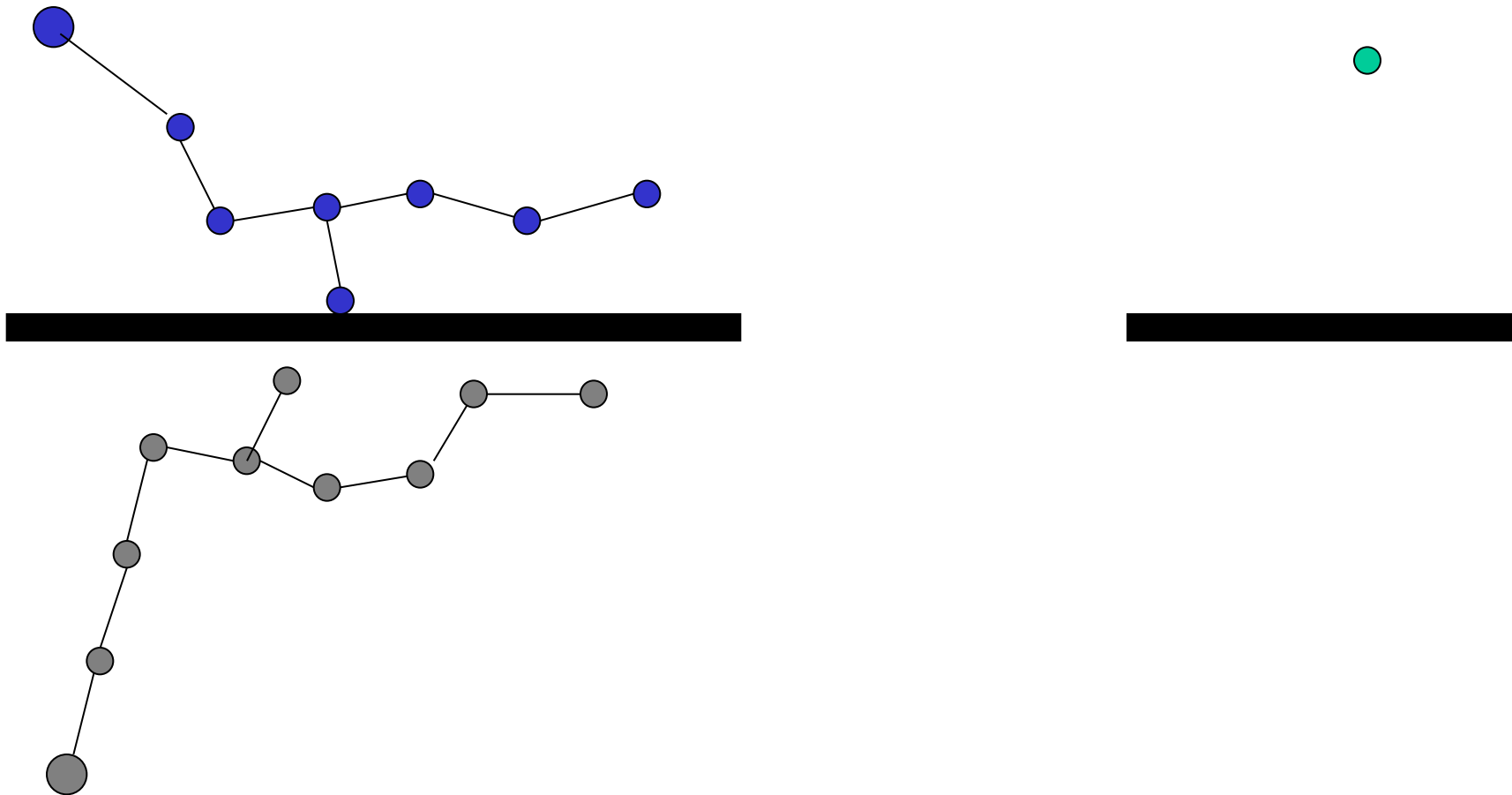

RRT-Connect: example

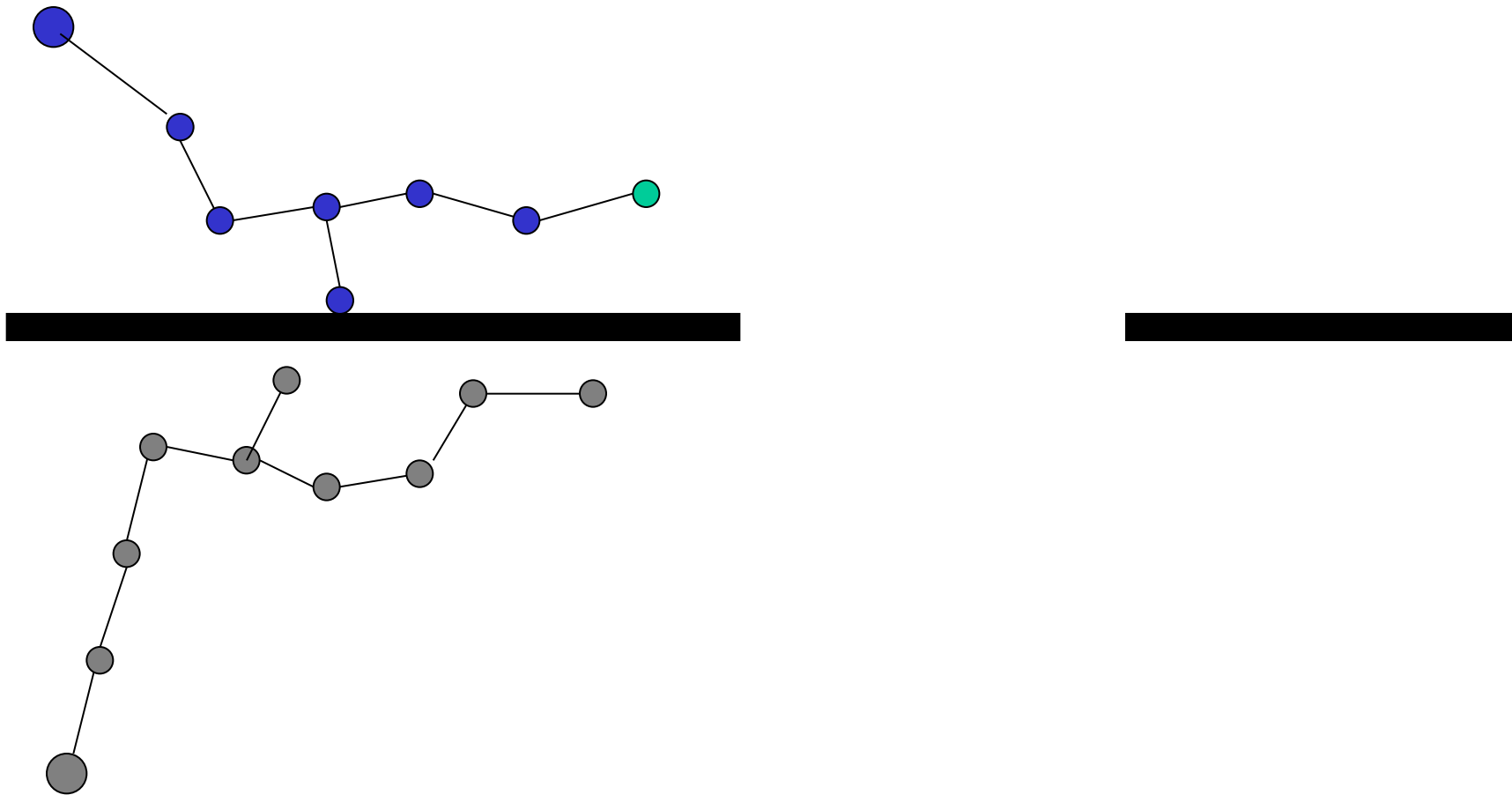

RRT-Connect: example

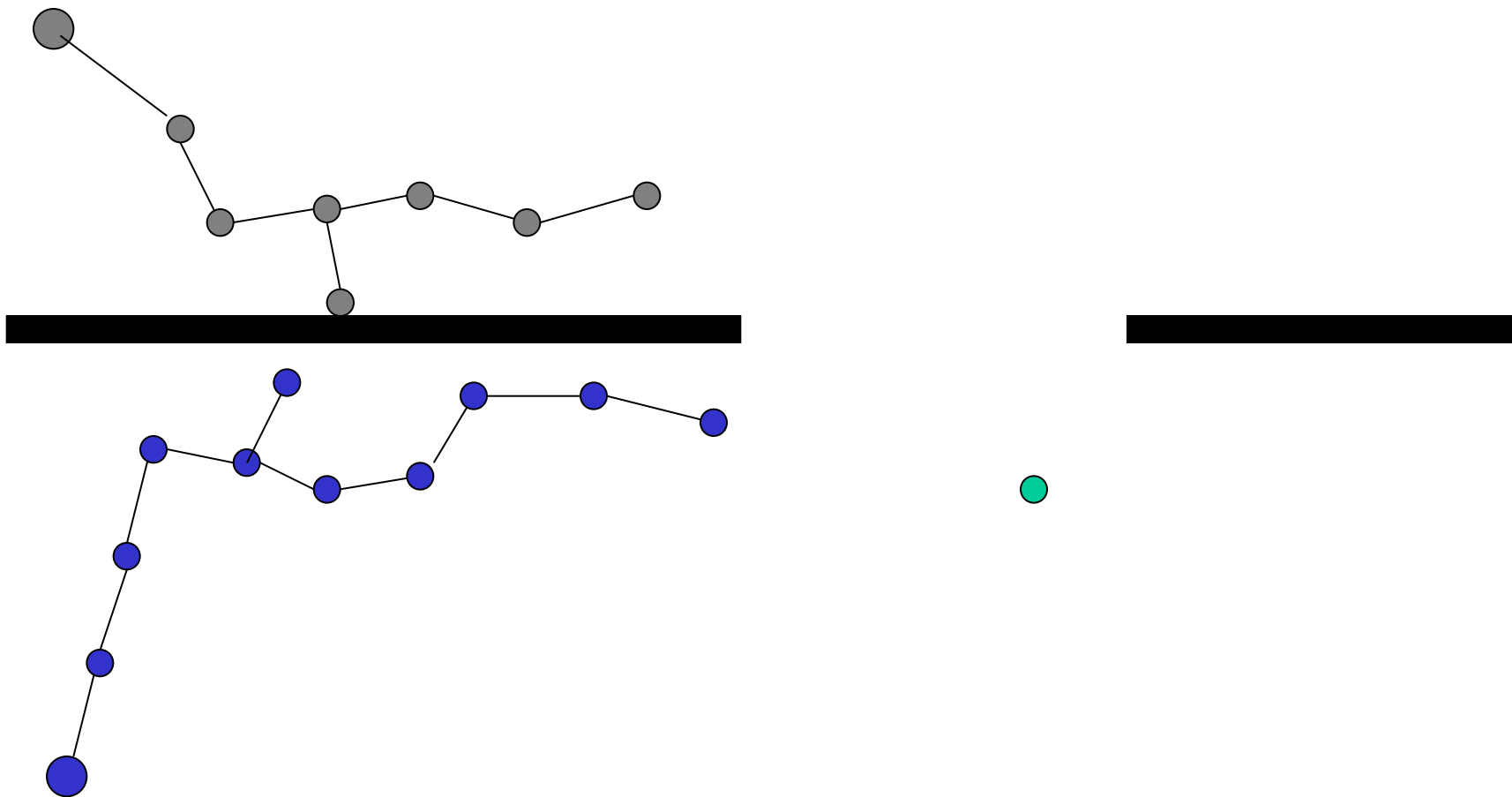

RRT-Connect: example

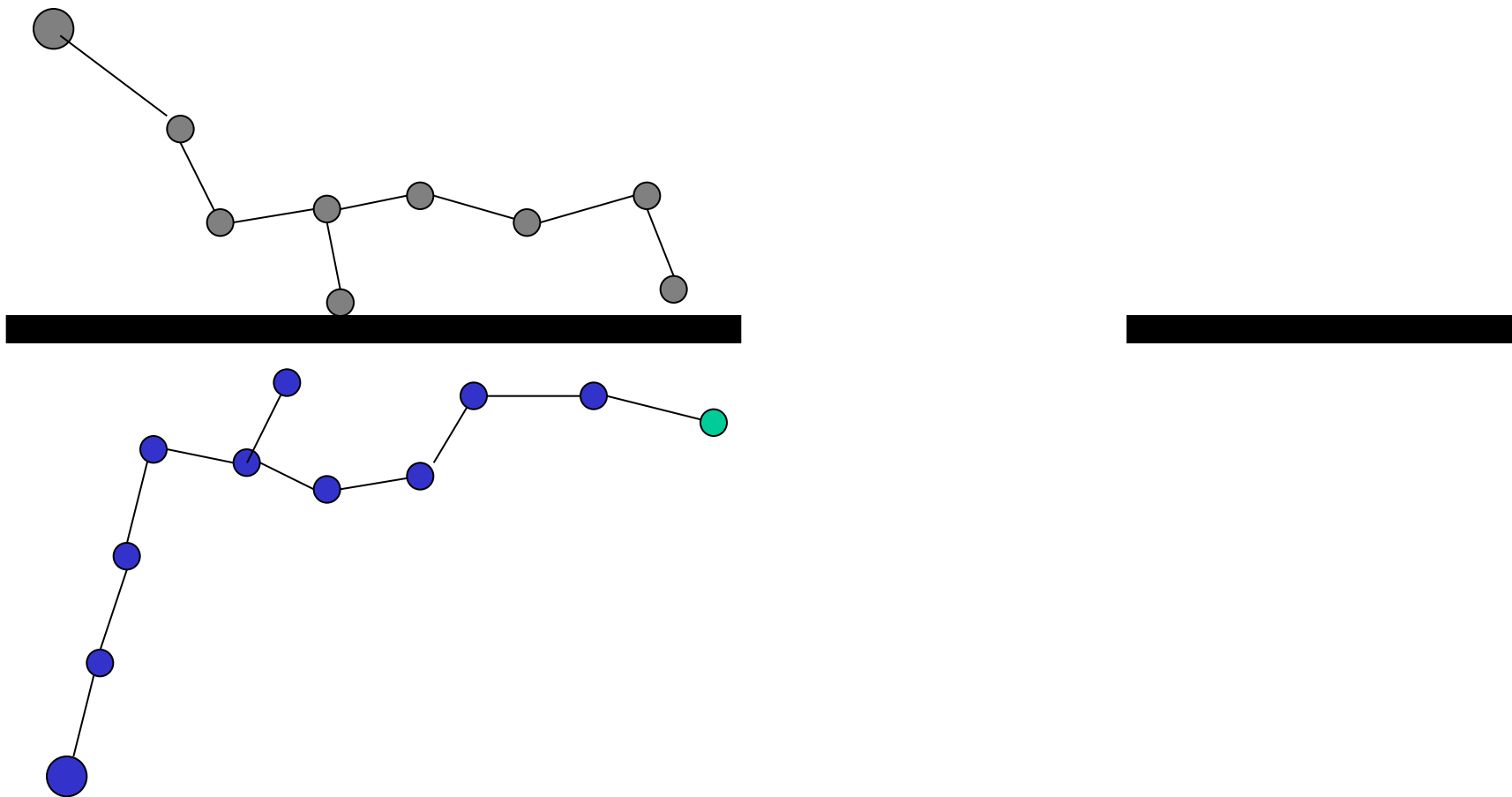

RRT-Connect: example

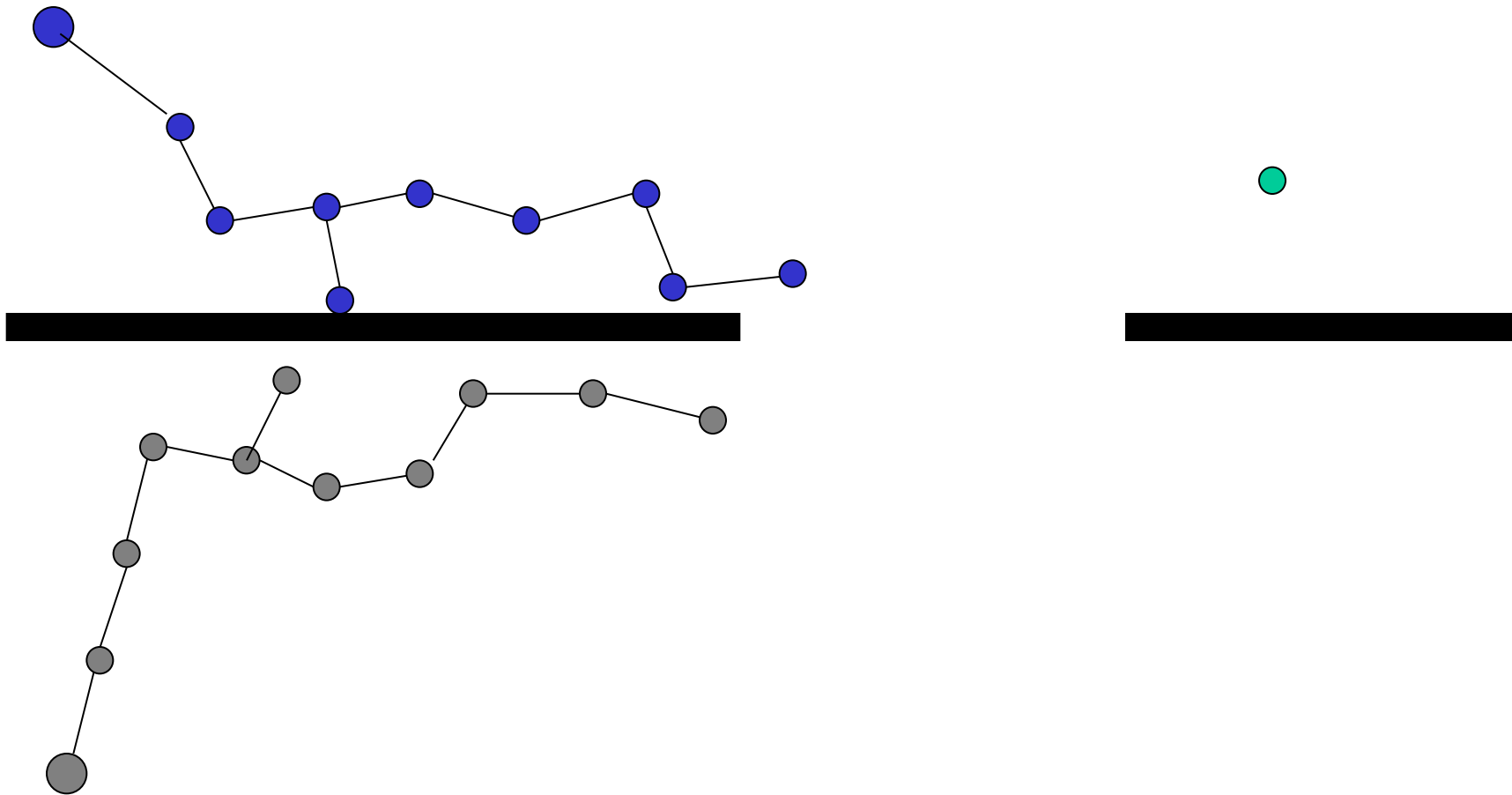

RRT-Connect: example

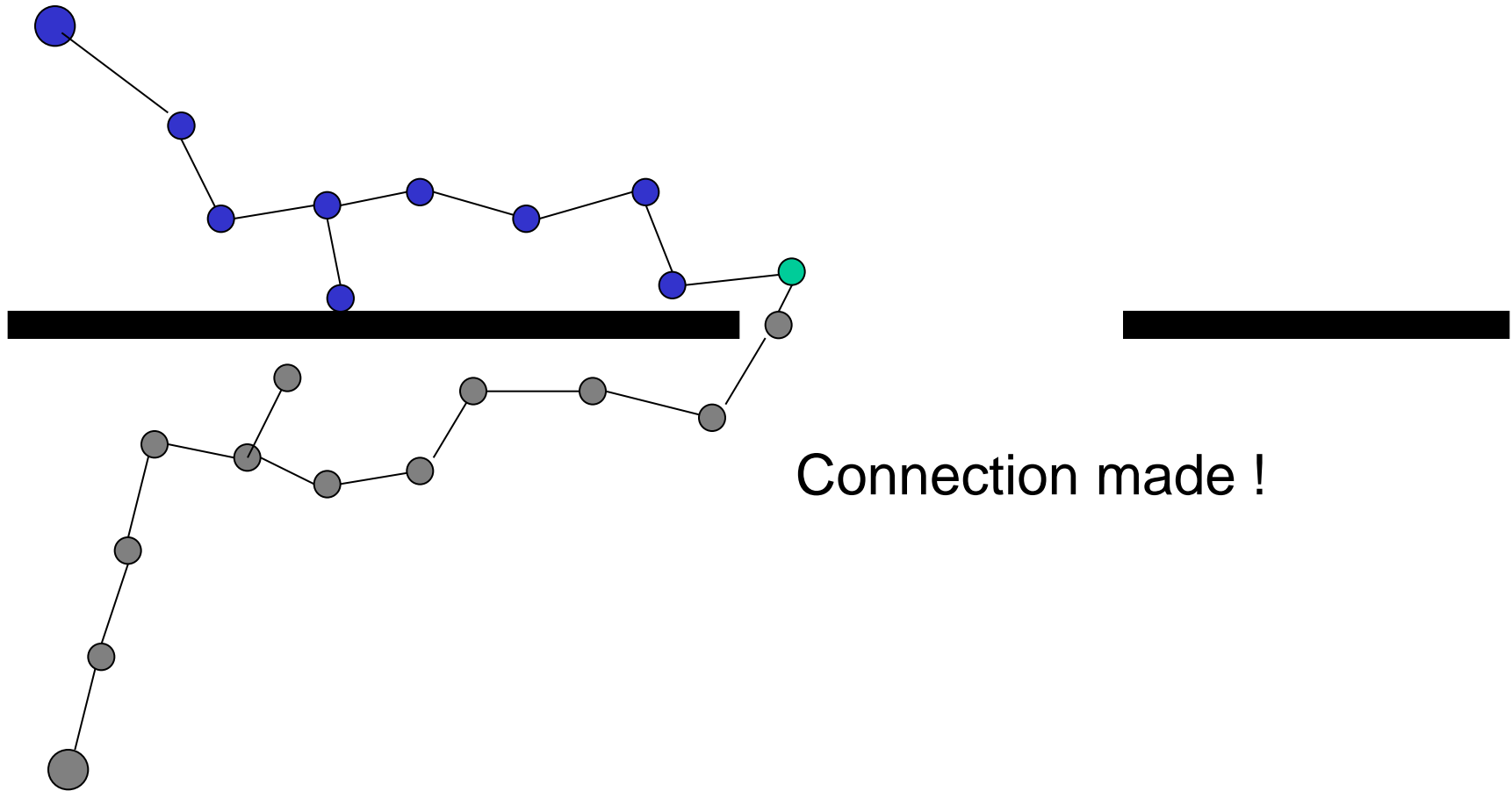

RRT-Connect: example

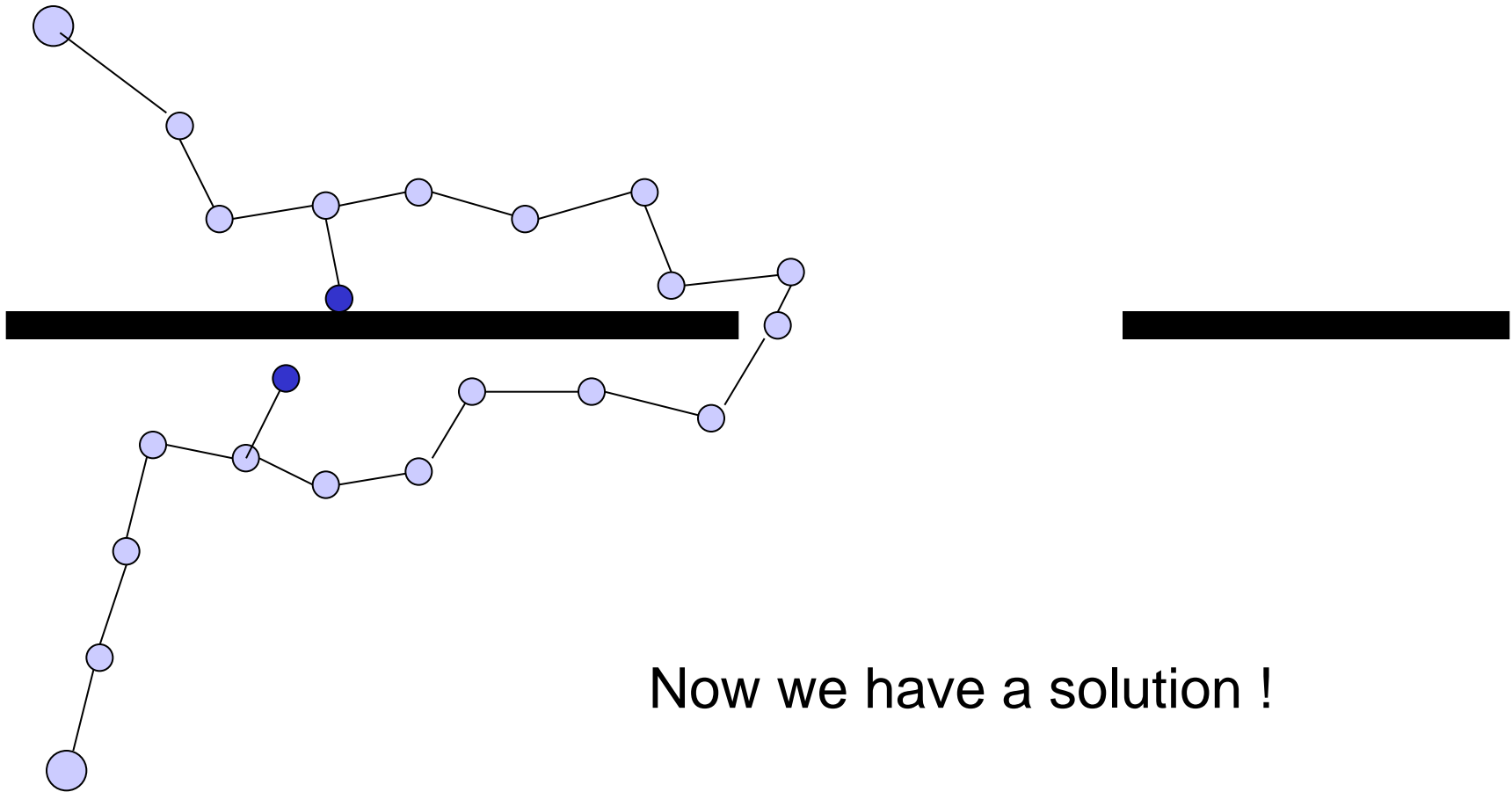

RRT-Connect: example

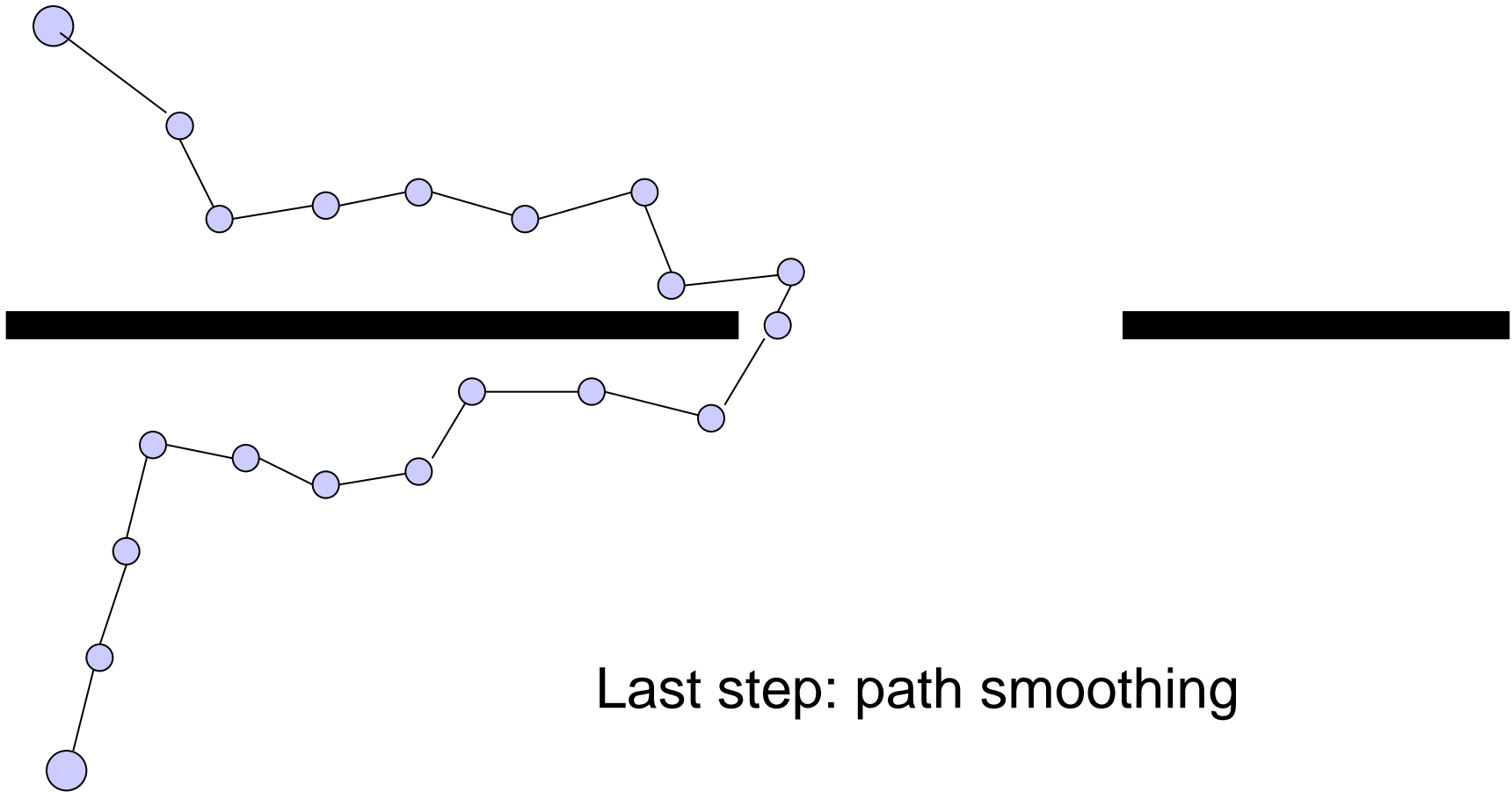

RRT-Connect: example

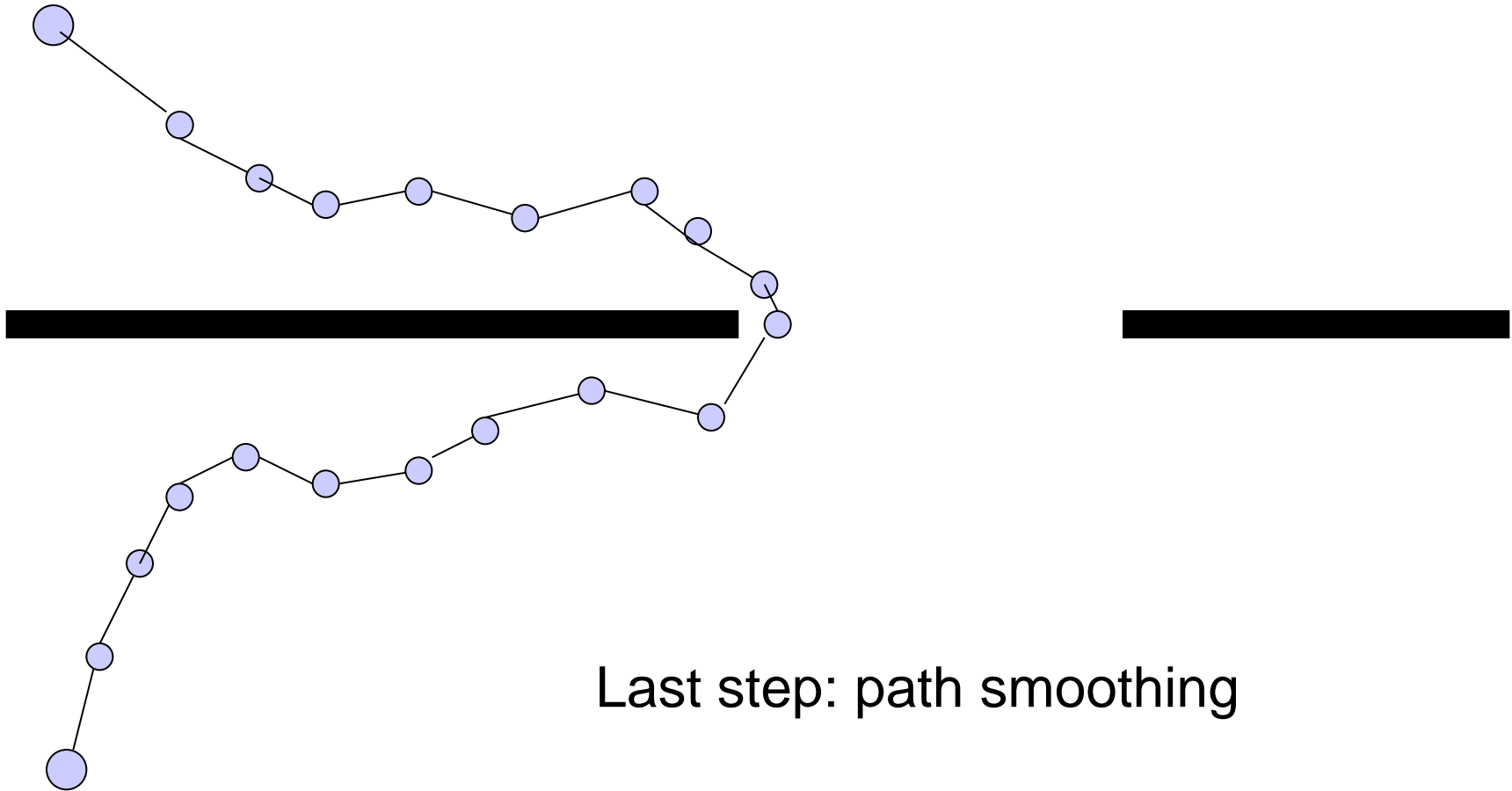

An RRT in 2D

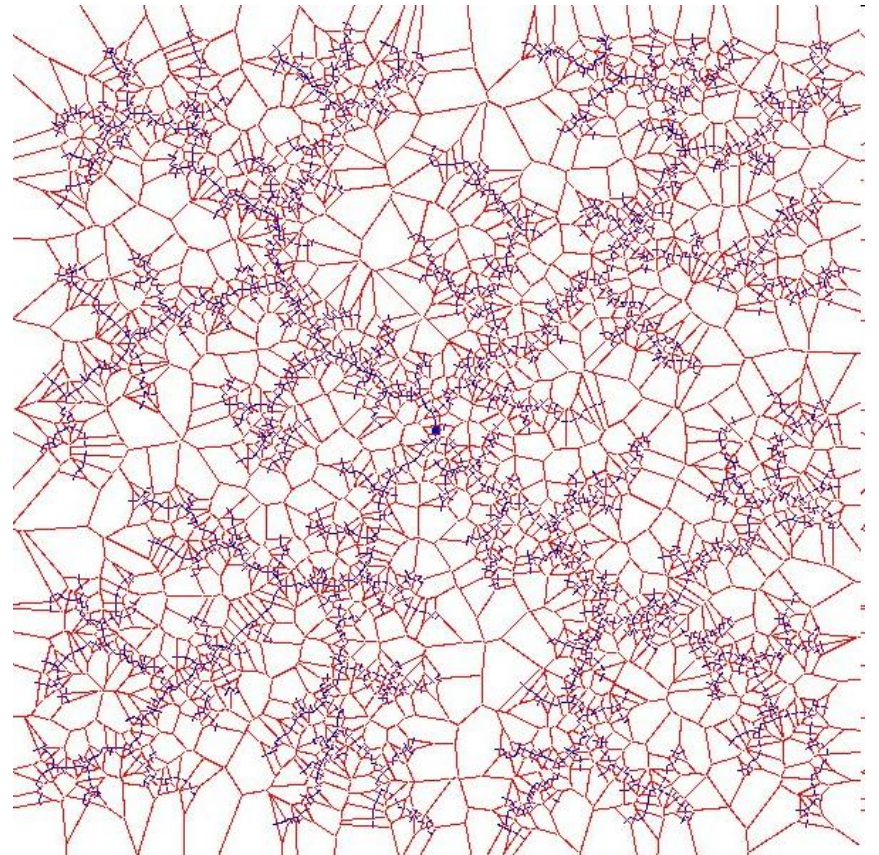
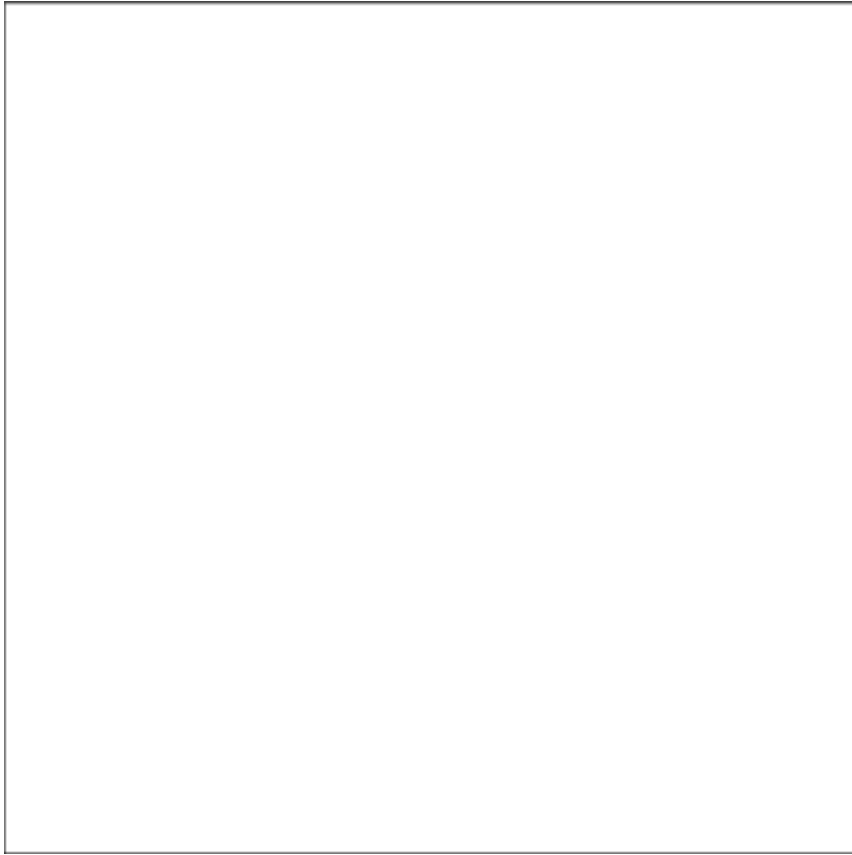

Example from: http://msl.cs.uiuc.edu/rrt/gallery_2drvt.html

A Puzzle solved using RRTs

The goal is to separate the two bars from each other. You might have seen a puzzle like this before. The example was constructed by Boris Yamrom, GE Corporate Research & Development Center, and posted as a research benchmark by Nancy Amato at Texas A&M University. It has been cited in many places as a one of the most challenging motion planning examples. In 2001, it was solved by using a balanced bidirectional RRT, developed by James Kuffner and Steve LaValle. There are no special heuristics or parameters that were tuned specifically for this problem. On a current PC (circa 2003), it consistently takes a few minutes to solve.

Lunar Landing

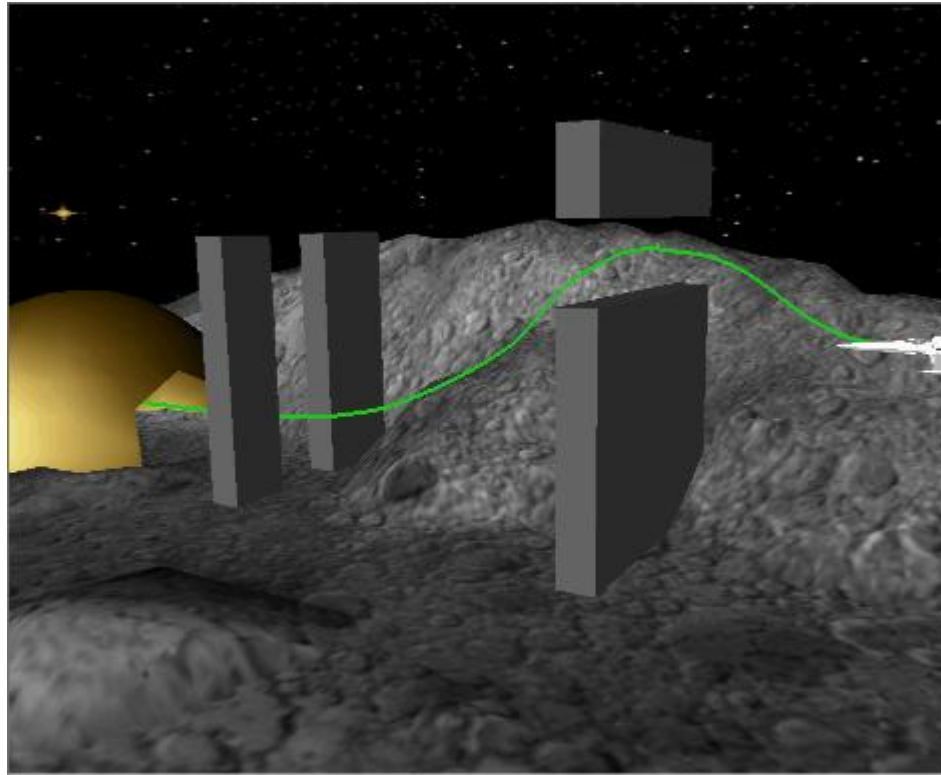

The following is an open loop trajectory that was planned in a 12-dimensional state space. The video shows an X-Wing fighter that must fly through structures on a lunar base before entering the hangar. This result was presented by Steve LaValle and James Kuffner at the Workshop on the Algorithmic Foundations of Robotics, 2000.